

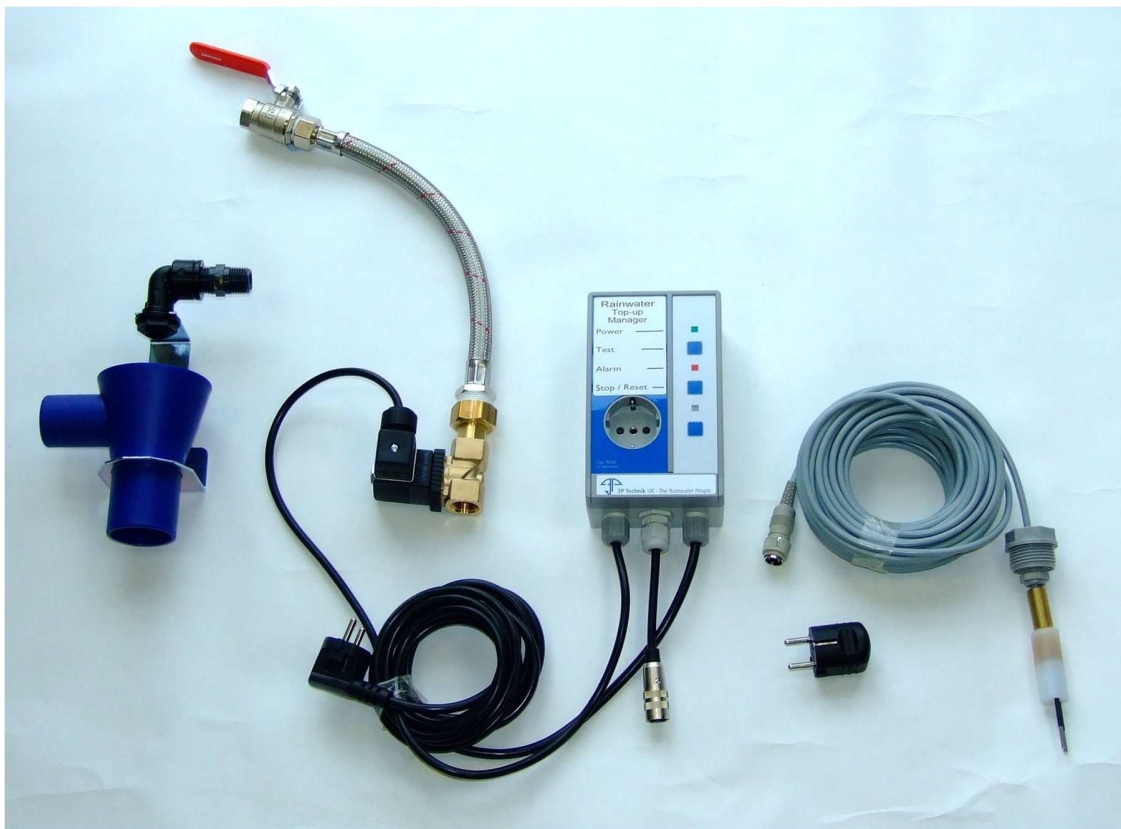

# Operating Instructions for 3P Mains Water Top-UP Set Compact



**ART: TCA5000950**

# Contents

<b>Contents</b> .....	<b>2</b>
<b>Product Description</b> .....	<b>3</b>
Component Listing .....	4
<b>Handling and Storage, Pre-installation</b> .....	<b>4</b>
<b>Installation</b> .....	<b>5</b>
Site Selection for the 3P Controller Unit.....	5
The 3P Tundish and bracket assembly .....	5
The Level Probe, a Conductivity Probe .....	6
<b>Operation</b> .....	<b>7</b>
Control Unit Operation .....	7
LED Indicators.....	8
Internal Jumper Settings .....	9
<b>Troubleshooting Guide: an “At Site Level” Fault Finder</b> .....	<b>10</b>
<b>Full Technical Specification</b> .....	<b>12</b>
Control Unit.....	12
Level Probe.....	12
Solenoid Valve.....	12

## Product Description

Automatic mains water top-up for rainwater tanks with leak detection feature and pump dry-run protection.

This unit is primarily designed to work with automatic pumps, i.e. pumps which are self- controlling by having a pressure switch controller built in to the pump. If you are in any doubt, please consult a professional. Your supplier can advise you.

You will need to Commission an automatic pump, which needs to feed into a water tight delivery network. If you are in any doubt, please consult a professional. Experienced Rainwater Harvesting (RWH) commissioning professionals are available to assist you. Failure to commission an automatic pump may invalidate your warranty. A guide to commissioning is available as an Appendix to this document. A pressure vessel will prolong the life of automatic pumps.

This is a reliable electronic controller that will give decades of trouble free service, once correctly installed.

## Component Listing

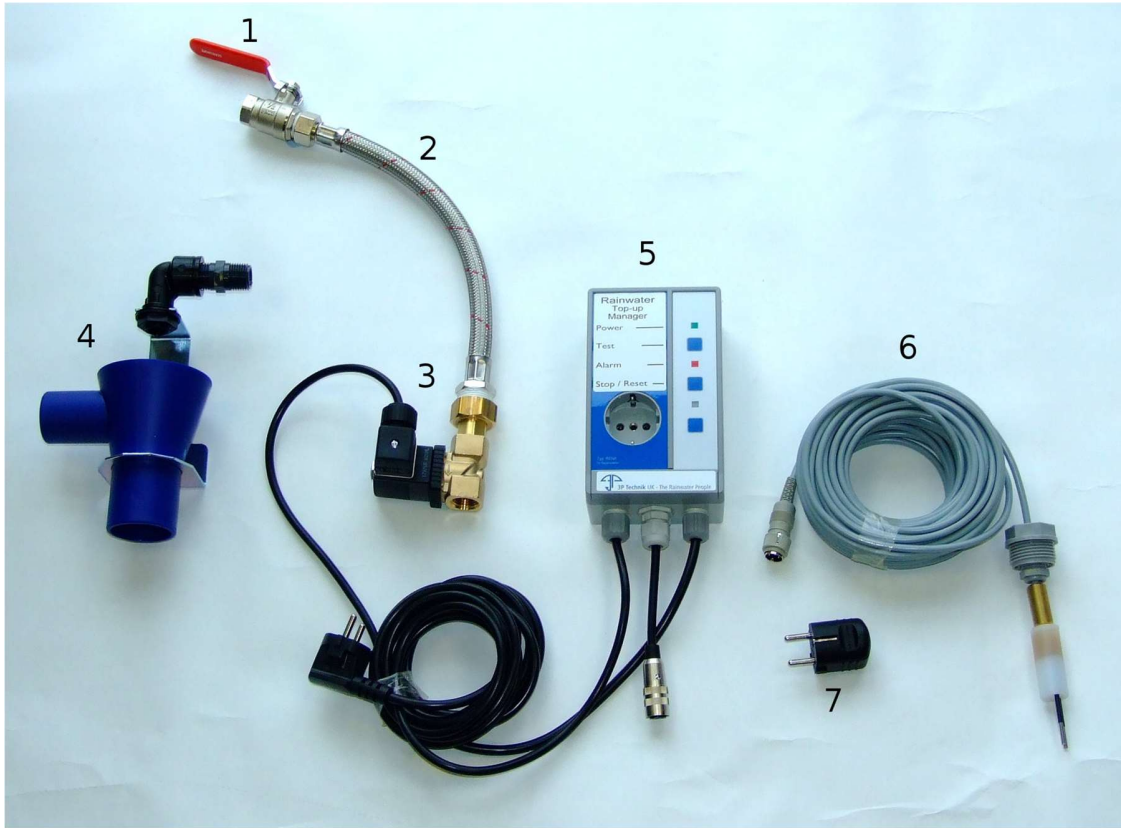

1. Ball Valve, for isolating mains water supply.
2. 30cm Braided Steel Flexi Hose with Isolation Valve. To mains water feed.
3. Solenoid Valve.
4. 3P Tundish with Steel Wall Bracket. DN 40 Overflow. DN 50 Outlet.
5. Control Unit Module.
6. Level Probe, 15m standard.
7. "Schuko" (European) Mains Plug. This is supplied in order to allow you to connect any pump to the European style mains socket on the front of the Unit.

## Handling and Storage, Pre-installation

- Do not leave the Control Unit or solenoid valve outdoors in the rain. They are not IP68 waterproof. Do not store or use in a location subject to freezing temperatures. This may include some outbuildings and uninsulated loft spaces.
- This is not an armoured or heavy-duty appliance, it will not survive impact and drops, crushing, etc. Do not leave on the floor. If damaged do not use it.
- Do not store with or upon cement, sand, plaster, etc. These materials will corrode the circuit board (and cause cosmetic damage).

## Installation

### **Site Selection for the 3P Controller Unit**

We recommend installation be carried out by a qualified electrician.

The Control Unit and Solenoid Valve must be mounted indoors in a dry place. Do not install in a location subject to freezing temperatures.

It can be wall mounted using the supplied fittings.

**NOTE: It is not a waterproof unit. DO NOT install in a tank turret.**

3P strongly recommends wiring the unit on a dedicated circuit, protected by a 10A Type C circuit protective device, in accordance with current best practice and regulatory requirements as defined by BS 7671, current IEE wiring regulations, and Part P of Building Regulations (where applicable). If in any doubt consult a qualified electrician.

There are a wide variety of pumps supplied in the UK rainwater market, some with 2 pin "Schuko", and some with 3 pin UK plugs. A 2 pin "Schuko" plug can plug directly into the plug socket on the face of the unit. If your pump has a 3 pin UK plug there are two options available.

- Change the pump's plug to a 2 pin Schuko plug (one is supplied with this kit).
- Use an earthed 2 pin Schuko to 3 pin UK socket adapter to plug into the Control Unit's pump socket (not supplied).

**SAFETY NOTE – European style Schuko plugs are not protected with a fuse, therefore it is vital the controller is installed on a 10A fused outlet to protect both the pump and controller.**

If in any doubt you MUST consult a qualified electrician.

### **The 3P Tundish and bracket assembly**

The 3P Tundish acts as a Type AA air gap to comply with BS EN 13076: Devices to prevent pollution by backflow of potable water. The 3P Tundish itself and its' ½" feed nozzle are both freely rotatable in the wall mounting bracket.

Install the 3P Tundish so that the potable water feed can gravity flow freely into the tank. Check the rate of delivery of potable water does not exceed the capacity of the connected hose/pipework to reach the tank at your site, without backing up. This is part of the Commissioning of your rainwater harvesting system installation process.

The 3P Tundish outlet to the tank (Nominal OD 47mm, ID 39mm) can be connected using 2" hose or with a 50mm MDPE Compression fitting, usually reducing to 32mm minimum, or using Waste Pipe at 50mm.

Note the 3P Tundish has an optional overflow. This is recommended and particularly useful if the top-up feed pipework to the underground tank gets blocked, as it will then likely prevent flooding of the room where the Controller is located. The overflow can be connected with a Universal Waste Adapter. (Product Code 5000411UWC).

## The Level Probe, a Conductivity Probe



The supplied conductivity Level Probe is used as a minimum water level detector in the rainwater tank. The standard length of cable supplied is 15m. This can be extended to order, up to 100m. It carries a very low voltage/current.

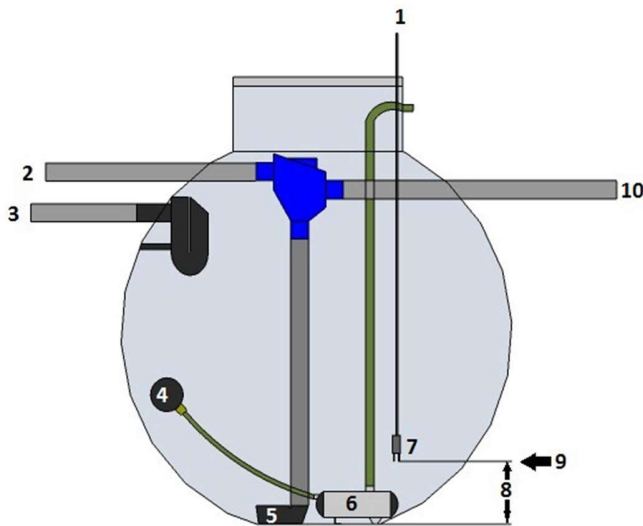

1	To Control Unit (from level probe)
2	Water From Roof
3	Max Water Level (overflow)
4	Floating Intake
5	Calmed Inlet
6	Pump
7	Level Probe set 200mm above pump
8	Approx. 0.3-0.4 m (guide only)
9	Minimum Water Level
10	Sewer Connection

Fix the Level Probe in the tank so that it is suspended approximately 0.3 to 0.4 metres above the bottom, depending on the shape of the tank and position of pump inlet. It should be positioned to ensure there is no risk of cavitation or air entrainment to the pump inlet. If in doubt you **MUST** consult an approved and qualified plumber. The height of the Level Probe determines the minimum water level of the tank at which the pump will run.

The Level Probe works by conductivity. When the Level Probe's contacts are immersed in water a circuit is completed and the control unit detects this. When the prongs of the probe come out of the water, topping up is activated.

Note: The Level Probe's length of cable can be extended to a maximum of 100m.

**OPERATIONAL ADVICE NOTES – Ensure that the tank is entirely free of debris before installing a pump and this controller. Sand, grit, cement and even plastic swarf from manufacturing and other**

*debris will quickly clog any filters and may damage the pump's internal parts and the pump's impellers, prematurely shortening the operational life of the system, and invalidate pump and other component warranties. The potable feed pipework to the solenoid must also be clear and free of debris.*

**Maintenance Advice** – It is good practice to gently clean the probe at intervals of three years or whenever checking the tank.

## Operation

### Control Unit Operation

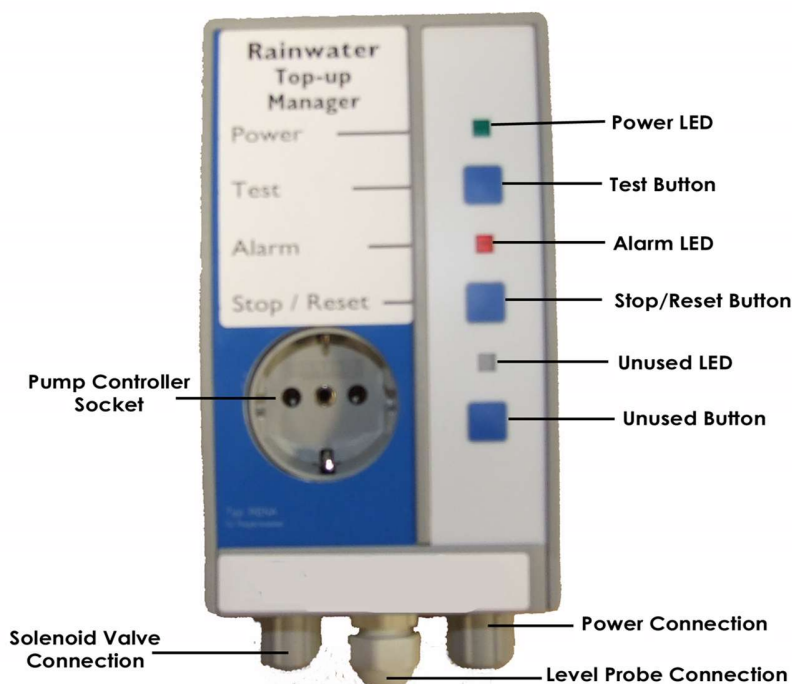

**Test button:** Pressing this when the Solenoid Valve is closed will momentarily open and close the Solenoid Valve.

**Stop/Reset button:** Closes the solenoid valve and shuts off power to the pump. The Alarm LED will flash.

A second press will reset the controller to its usual working state.

When the Control Unit is powered up:

**High Water Level:** If the Level Probe is immersed in rainwater, (i.e. below the rainwater level in the tank) then the green LED remains on, there is power to the pump socket (so a connected pump will then run) and the solenoid valve is closed (i.e. not topping up).

**Low Water Level:** If the rainwater level falls below the Level Probe a top-up cycle will begin. The green LED flashes and the Solenoid Valve opens to allow mains water to flow via the Tundish and so into the rainwater tank. During the top-up cycle the pump will be turned off (power to the pump is isolated during topping up).

Once the water level reaches the Level Probe again the pump is re-enabled, and so allowed to run. The solenoid valve will remain open for a further ONE minute before closing. The top-up cycle is now complete and the green LED changes from flashing to solid.

**Self Maintenance:** The Control Unit will momentarily open and close the Solenoid Valve three times a week to prevent blockages. This process takes place automatically.

**Safety Shutdown:** During a top-up cycle, if the water level in the tank has not reached the level probe after 30 minutes of topping up, the unit will shut off the pump and close the solenoid. The red alarm LED lights to indicate that there is one or more of: 1. a leak or blockage in the delivery pipework feeding to the tank, 2. a failure of the tank itself, or 3. a problem with the solenoid valve.

### **LED Indicators**

Green - Solid	Normal Operation. Solenoid Valve closed. Pumps runs as usual. Water level sufficient.
Green - Flashing	Top-up cycle in progress. Solenoid Valve open (topping up). Pump is disabled (switched off) during top-up.
Red - Solid	Safety shutdown. Top up failed.
Red - Flashing	Control Unit stopped manually (stop/reset button has been pressed by an operator).

## Internal Jumper Settings

This can be adjusted to increase the duration of the top-up cycle, and should be set by 3P in advance, or otherwise adjusted by a qualified electrician or instrumentation technician.

**The power supply MUST be disconnected before opening the Control Unit, there are hazardous voltages inside.**

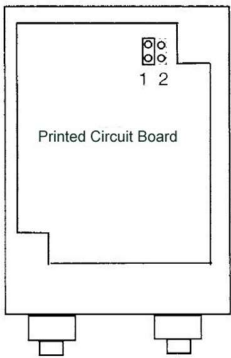
 <p>The diagram shows a rectangular Printed Circuit Board (PCB) with two terminal blocks at the bottom. At the top right, there is a small component labeled '1 2' with two positions. Position 1 is the default setting, and position 2 is an alternative setting.</p>	<p>For larger tanks and flow rates the jumper can be moved from the default position 1, to position 2. This position tops up much more water into the tank. (see below).</p> <p>In position 2 the pump shut-off delay and alarm delays are also increased accordingly.</p> <p>If in any doubt please consult a qualified electrician or electronic technician.</p>
--	--

	<p><b>Attention!</b> The Control Unit must only be opened when it has been ensured that there is no power to the unit.</p>
--	--

Jumper Setting	Delay before pump shut-off during top-up	Top-up duration after level probe is reached	Safety Shutdown delay
1	15 sec	1 min	30 min
2	10 min	20 min	45 min

**Jumper setting 1:** The pump will turn off 15 seconds after the beginning of a top-up cycle. The Solenoid Valve will close 1 minute after the water level reaches the Level Probe. If the water level doesn't reach the Level Probe within 30 minutes the unit alarms.

**Jumper setting 2:** The pump will turn off 10 minutes after the beginning of a top-up cycle. The Solenoid Valve will close 20 minutes after the water level reaches the Level Probe. If the water level doesn't reach the Level Probe within 45 minutes the unit alarms.

## Troubleshooting Guide: an “At Site Level” Fault Finder

Symptom	Possible Faults	Solution
Solid Red LED – Controller has alarmed and shut down.	Solenoid is blocked	Press Reset, then test solenoid by pressing Test button. If solenoid clicks but no water flows, check the supply pipework and flexi-hose for blockages. If supply is clear but solenoid does not function, replace solenoid (call technical support).
	Solenoid has failed.	If solenoid does not click, check wiring from solenoid to controller for possible damage. If OK replace solenoid (call 3P Technical support).
	Solenoid functions normally, tundish overflows	The supply pipe from tundish to tank is blocked. Clear blockage and retest.
	Solenoid functions normally, tundish does not overflow but tank does not fill.	Check tundish to tank pipework by visually looking for top-up water entering the tank. If no water is present, suspect failure in pipework. If water is present suspect tank failure.
Flashing red LED – Controller has been stopped Manually.	No fault.	Press the stop/reset button to reset the controller.
Top-up cycle is too frequent causing pump to be shut off during demand for water.	Too small a top-up time is selected.	Follow the Internal Jumper Settings instructions to change the jumper to position 2. Consult a qualified electrician before opening the Control Unit. If in any doubt please consult a qualified electrician or electronic technician.
Top-up cycle activates often, even when no water is drawn on demand.	Possible tank failure or fault (leak) in supply pipes from pump.	Shut down controller and pump and check tank water level periodically (during dry weather). If water level drops, suspect tank failure. Otherwise switch on controller and pump and check for leaks in outlet pipes from pump, and possible leaks of toilet float valves, etc. Consider a larger pressure vessel. Consult a professional adviser.

<b>Symptom</b>	<b>Possible Faults</b>	<b>Solution</b>
Controller does not function (no lights).	Internal fuse failure.  Controller or associated wiring has tripped the mains circuit breaker or RCD.	Have the controller's internal fuses checked by a qualified electrician and replaced if necessary. If the unit fails again, contact your supplier for replacement. If in any doubt please consult a qualified electrician or electronic technician.  Have the supply circuit checked by a qualified electrician. Check circuit breaker is of a suitable rating (10A Type B recommended), also test wiring insulation and earth. If the supply circuit is proved to have no fault, contact your supplier for replacement.
Pump does not run, top-up and other functions seem ok.	Pump failure.  Controller Damaged.	Unplug the pump and test separately.  The control unit can supply up to 10A at 240v to the pump. It may be damaged if this specification is exceeded.
For all other faults.	Contact your system supplier.	If your system supplier is no longer trading, you may consult 3P Technik UK.

## Full Technical Specification

### **Control Unit**

Dimensions (W x H x D):	97mm x 163mm x 62mm
Weight:	0.5 kg
Supply voltage:	AC 230-240 V 50 Hz
Nominal Power Consumption:	5w (excluding pump)
Internal fuse:	32 mA
Pump power outlet socket:	AC 230-240 V, max. 10 A (fused)
Mains Plug Fuse:	T 10 A
Operating Temperature Range Ambient:	0 °C to +40 °C
Electrical Protection class:	II (DIN 57 700)
Ingress Protection:	IP 20 (EN 60529)
Noise immunity:	According to EN 50082-1
Noise suppression:	According to EN 50081-1

### **Level Probe**

Supply voltage:	AC 6 V
Probe current:	1.2 mA
Cable length:	15m (max. 30m)
Dimensions of probe (L x Ø):	87mm x 30mm
Weight:	0.2 kg
Principle of operation:	Conductivity
Medium:	Clean water

### **Solenoid Valve**

Dimensions (W x H x D):	95mm x 80mm x 100mm
Weight:	0.5 kg
Supply voltage:	AC 230-240 V 50 Hz
Power consumption:	max. 5.5 VA
Connection cable:	3m
Mounting position:	Any
Medium:	Clean water
Maximum pressure:	12 bar
Flow rate at 4 bar inlet pressure and open outlet:	approx. 50 l/min
Connection:	Inlet: ¼" BSP union nut with in-line filter
Function:	Closed when de-energised
Protection:	IP 56 (EN 60529)
Outlet:	½" BSP female thread