



Rainwater Harvesting



Installation and maintenance instructions

Home Direct (Mains on Tap) System



1. GENERAL NOTES

The points described in these instructions must be followed correctly. If not correctly observed, any right to claim on the warranty may be refused.
Any missing instructions must be requested directly from us.
A complete check of all the items/components for possible damage must be carried out before the assembly or installation begins.
The installation must be carried out in a professional manner.

Safety

The relevant accident prevention regulations must be observed during all work.

The relevant regulations and standards must additionally be taken into consideration during installation, assembly, servicing, repair, etc.

The system or individual parts of the system must be installed by qualified specialists.

During all work on the system or parts of the system, the entire system must always be rendered inoperable and secured to prevent unauthorised reactivation.

Except in the event of work carried out in the tank, the cover of the tank must always be kept sealed, as this otherwise constitutes a maximum risk of accident. Only original GRAF covers or covers approved in writing by GRAF must be used.

GRAF offers an extensive range of accessories, all of which are designed to match each other and which can be extended to form complete systems. The use of accessories that have not been approved by GRAF results in the exclusion of the warranty/guarantee.

Identification obligation - Regulation

The water in these systems is not suitable for consumption or personal hygiene.

All pipe work and outlets of the water systems are to be labelled with the words "Not drinking water" either in words or graphically. (British Standard BS EN 16941-1:2018) so that after years of use, an accidental connection to the drinking water system is prevented. Even when correctly labelled it may possibly be mistaken, for example by children. For this reason, all the outlets of the systems process water must be fitted with child safe valves.

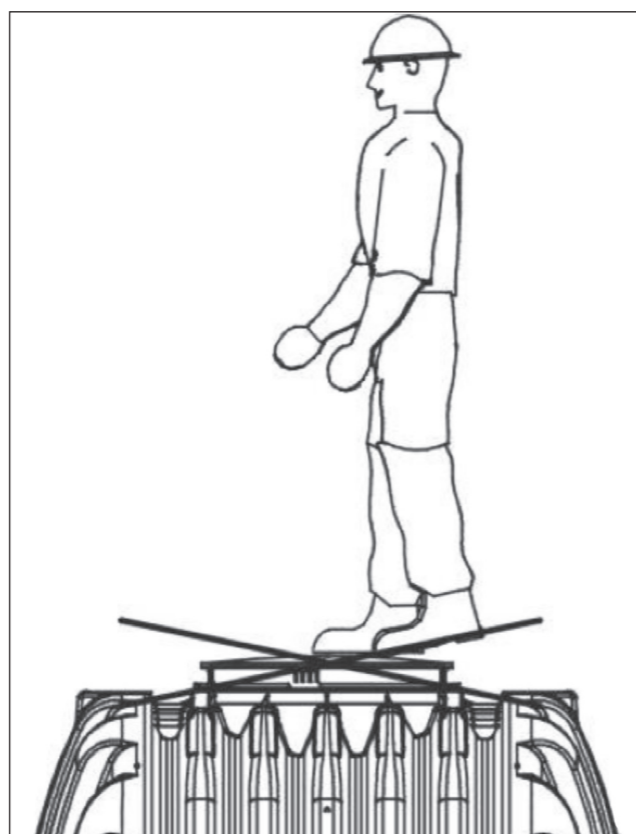

2. TECHNICAL DATA

Schematic drawing of Graf Home Direct (Mains on tap system) - Carat Tank

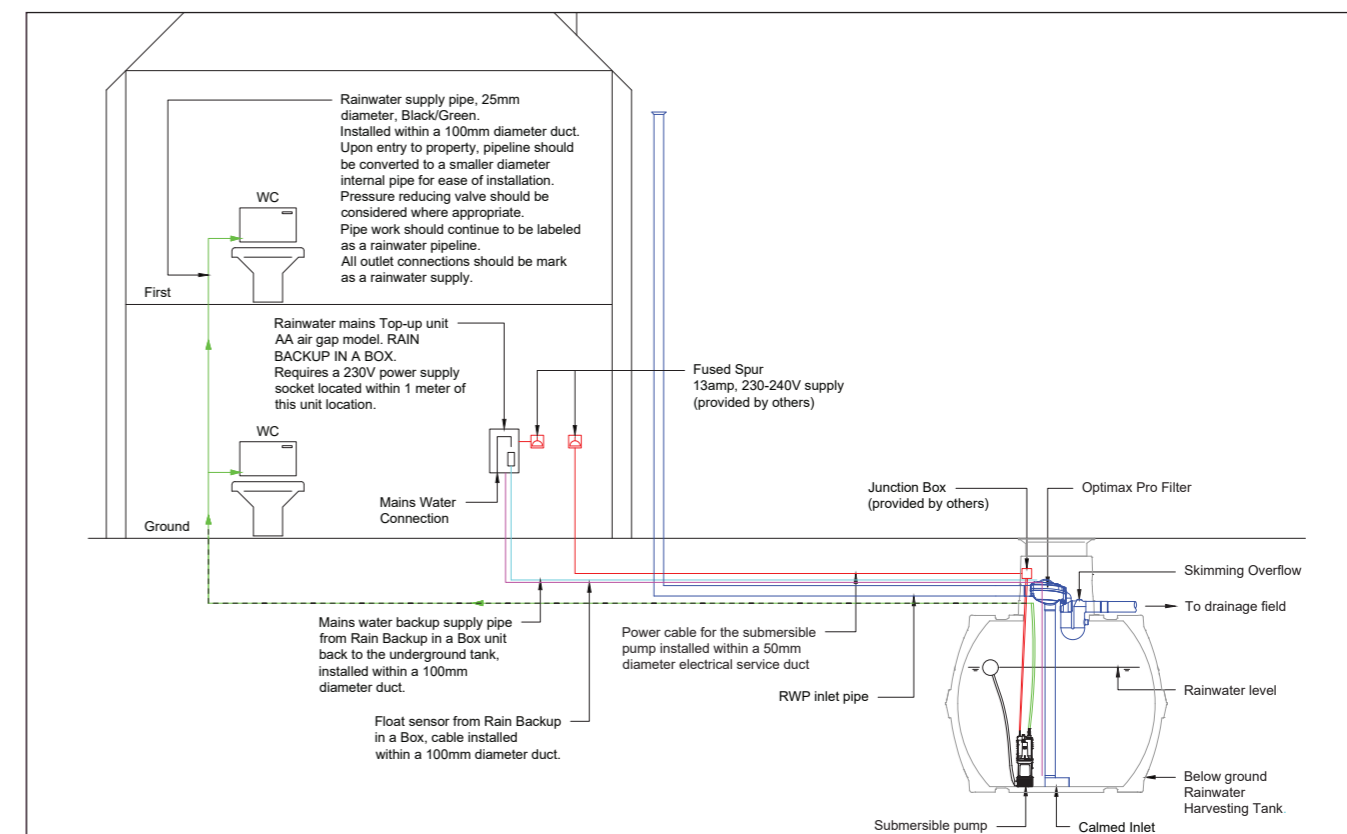

Schematic drawing of Graf Home Direct (Mains on tap system) - Platin Tank

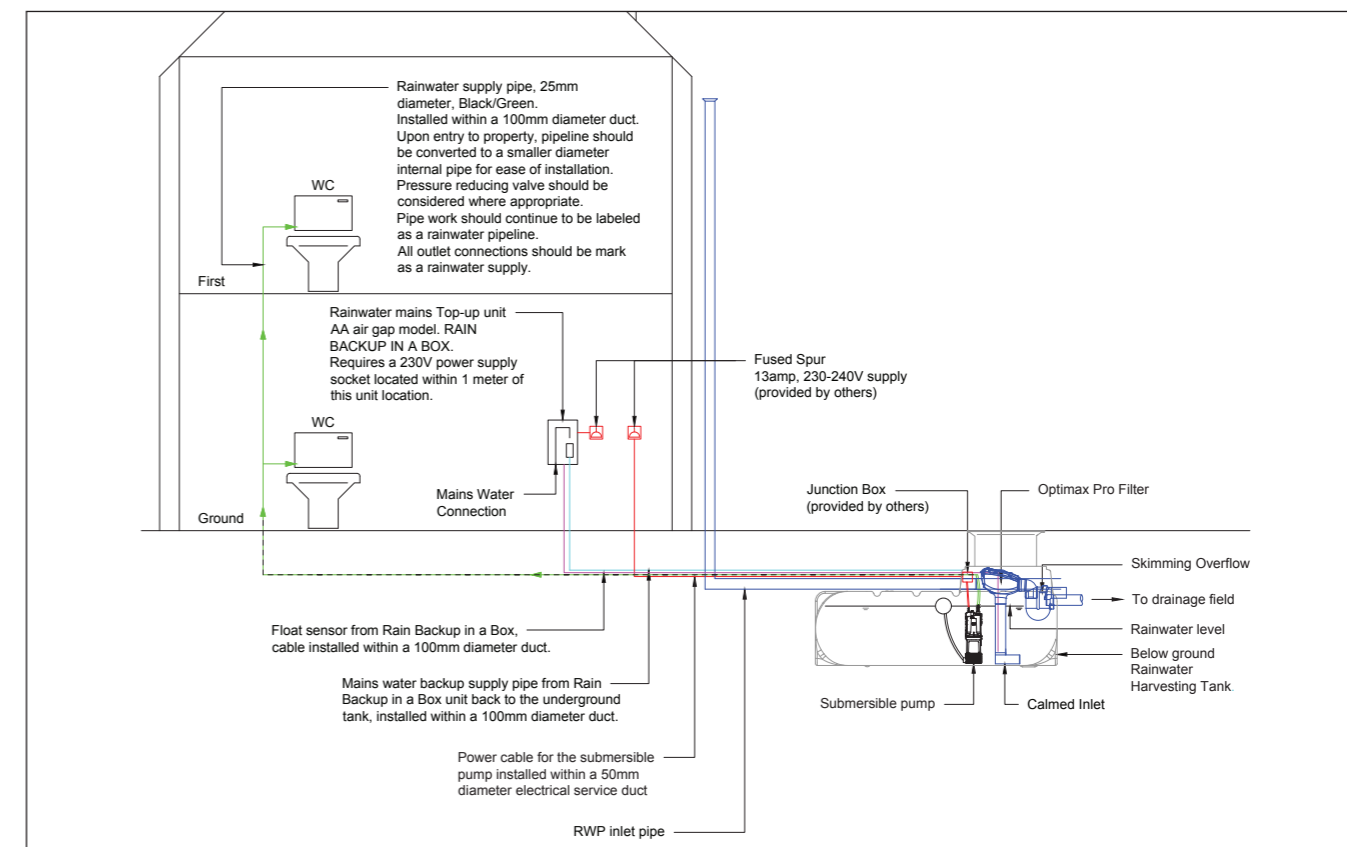

2. TECHNICAL DATA

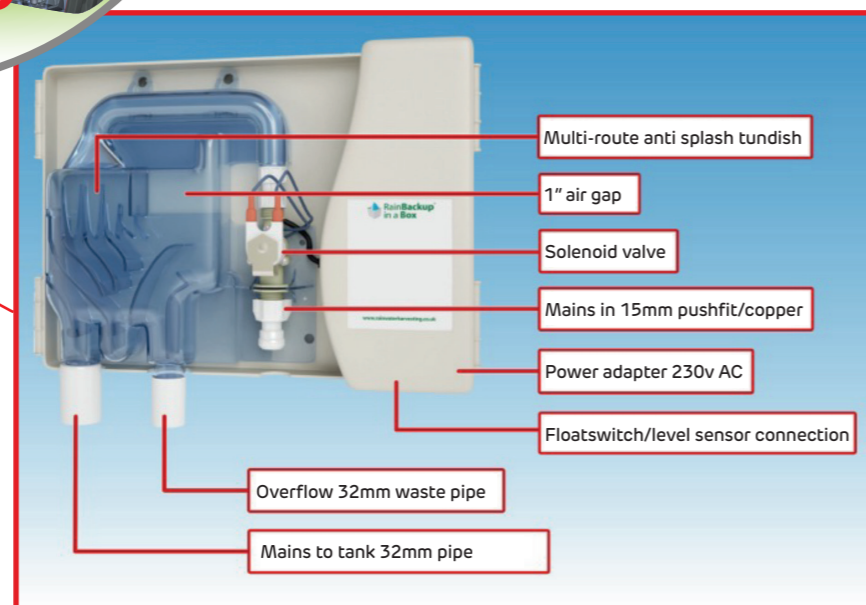
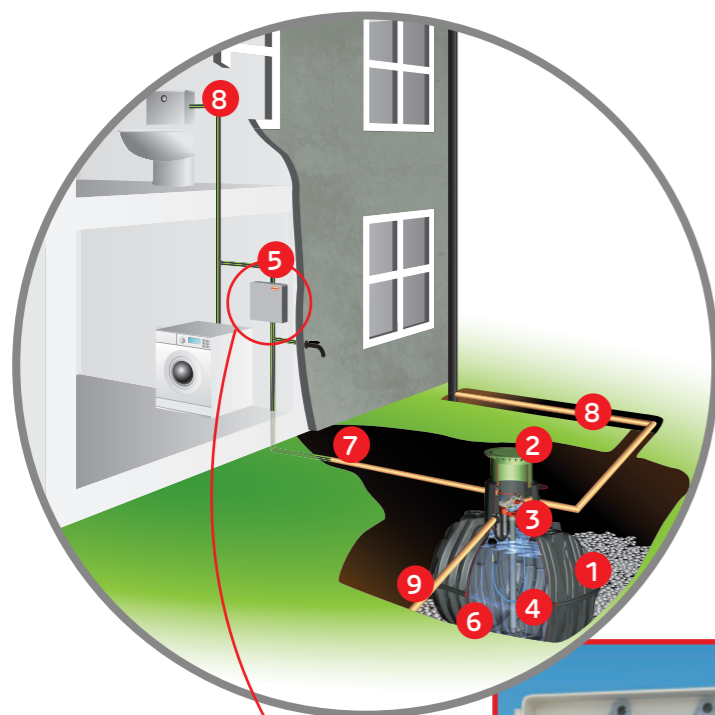

1.1 Scope of supply

1. Underground tank (choice of tanks available, sizes vary according to property type)
2. Telescopic lid (choice of telescopic lid available, depending on tank location)
3. Filter (Optimax/Minimax filter supplied in accordance with type of tank)
4. Submersible Pump with Floating Water Intake
5. Mains on Tap unit
6. Float sensor (connected from Mains on Tap unit to the underground tank)

1.2 Supplied by others

7. 100mm diameter duct pipe to contain; float sensor cable and rainwater feed
8. 100mm diameter drainage pipe connected from downpipes to the inlet at the top of the tank (all downpipes brought into one pipe for connection to the filter)
9. 100mm diameter pipe for overflow from the tank to mains drainage network or soakaway

2. TECHNICAL DATA

Plug-and-play mains water backup for rainwater harvesting systems.

This system guarantees water will be available to appliances in times of drought when the Rainwater tank is empty. The system uses a level sensor inside the tank to open a solenoid valve within the control unit when water reaches a critical level.

When the tank level triggers the level sensor, the PCB board allows 45 minutes of mains water restricted to 4 litres per minute (180 litres) to enter the tank once the float switch has reached the full position.

U.K. Building Regulations require that rainwater cannot possibly flow back into the mains water supply.

For this reason all mains backup devices must have an air gap where the mains water flows into the rainwater tank. The air gap in this system is an anti-splash tundish and overflow incorporated into one; the transparent blue moulded part. The level sensor is provided with 20 metres of cable and uses a push connection under the right hand panel.

The Mains on Tap Unit should be fitted inside the building where the occupiers can (when rainwater has run out) hear any mains water running from the solenoid valve. Wall mounting is with screws through holes in the back of the control unit.

The Mains on Tap Unit is reliant on a constant power supply, as such we recommend at least one WC is kept on mains water to prevent any disruption in the event of a power failure.

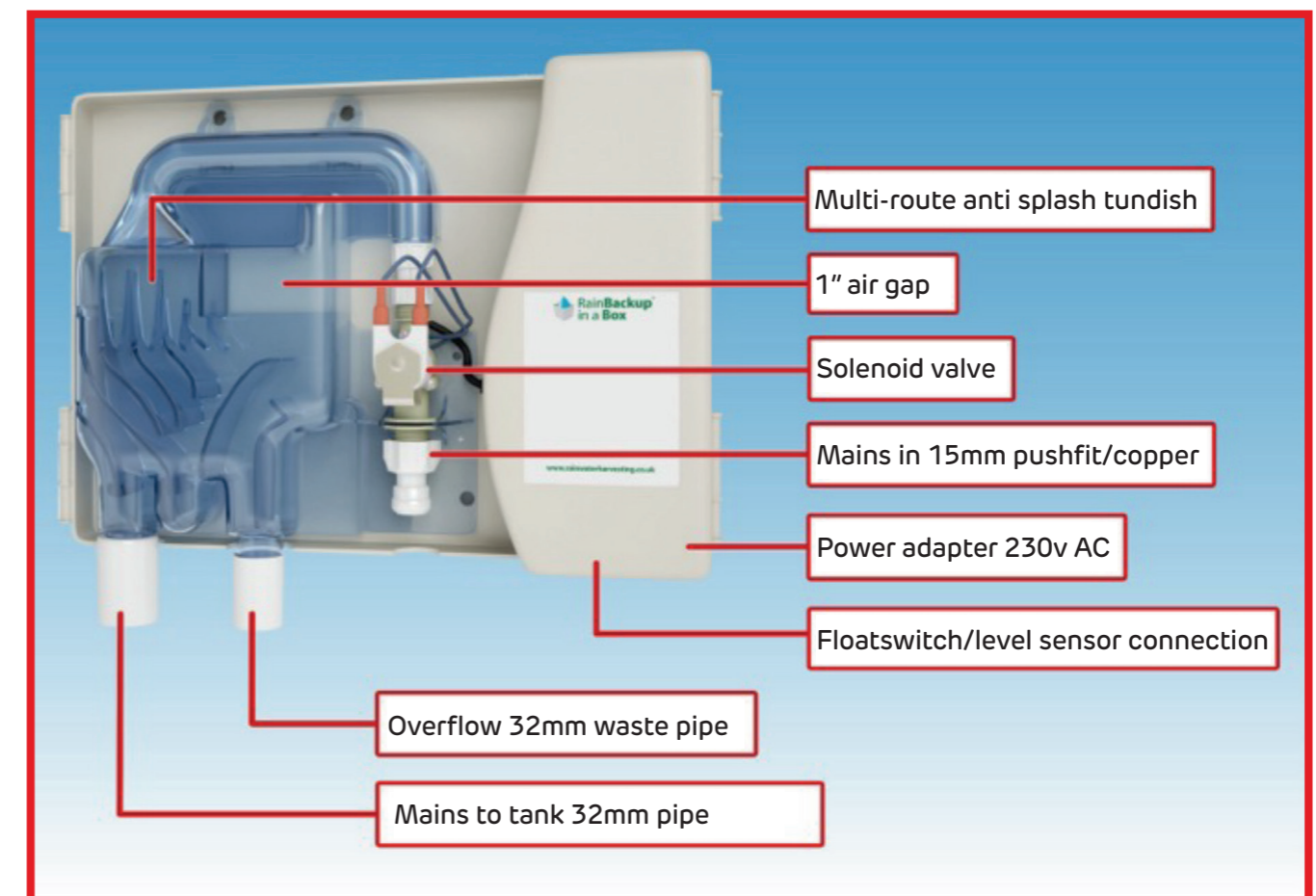

2. TECHNICAL DATA

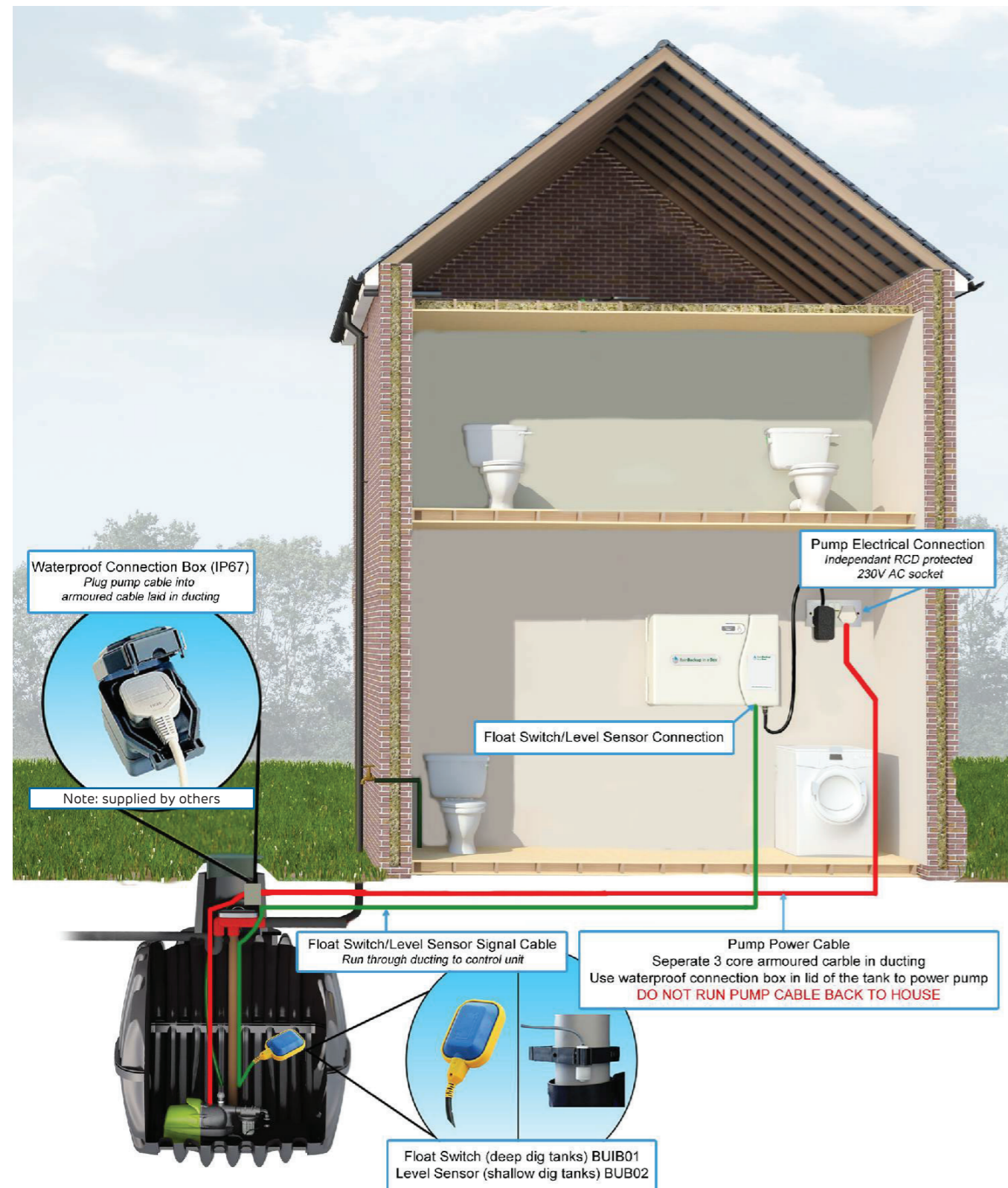

2. TECHNICAL DATA

Installation instructions

These instructions assume the exterior tank is fully fitted to the specification of the instructions provided.

Rainwater should be taken from roof space, through a filter into an underground storage tank and a pump to take the rainwater through a separate pipe network for toilets, washing machine and outdoor use.

1) Locate the best position for the Mains on Tap unit.

a. Inside the building where the occupiers can see and hear it, accessible for occasional checks.

b. Within a metre of a 220v AC wall socket into which to connect the plug.

c. Accessible to a mains water pipe.

d. Above the top of the underground storage tank so that the backup mains water flows by gravity.

2) The unit must be securely mounted flush to the wall and not angled in any way thus avoiding the possibility of water escaping from the 1" air gap. Then pipe the mains water to the inlet at the bottom right of the unit.

3) Pipe the outlet of the tundish using 32mm waste pipe from the bottom left of the unit to the rainwater storage tank. **The first 300mm must be a straight fall**, with the remaining pipe having sufficient fall for the water to run **under gravity** to the below ground tank. Any angle close to the unit risks the water backing up and flowing back out of the tundish. In most installations this outlet can be channelled to the closest possible rainwater downpipe from the roof. This backup water supply does not have to be piped separately to the storage tank.

4) The overflow pipe in the middle of the Mains on Tap unit should flow to the exterior through a pipe which offers no constriction. It is designed to avoid flooding of the house if the pipe from the tundish to the underground tank is blocked up, and to provide a visual alert to the building occupants. Run the overflow to the exterior of the building to discharge over the ground or gully.

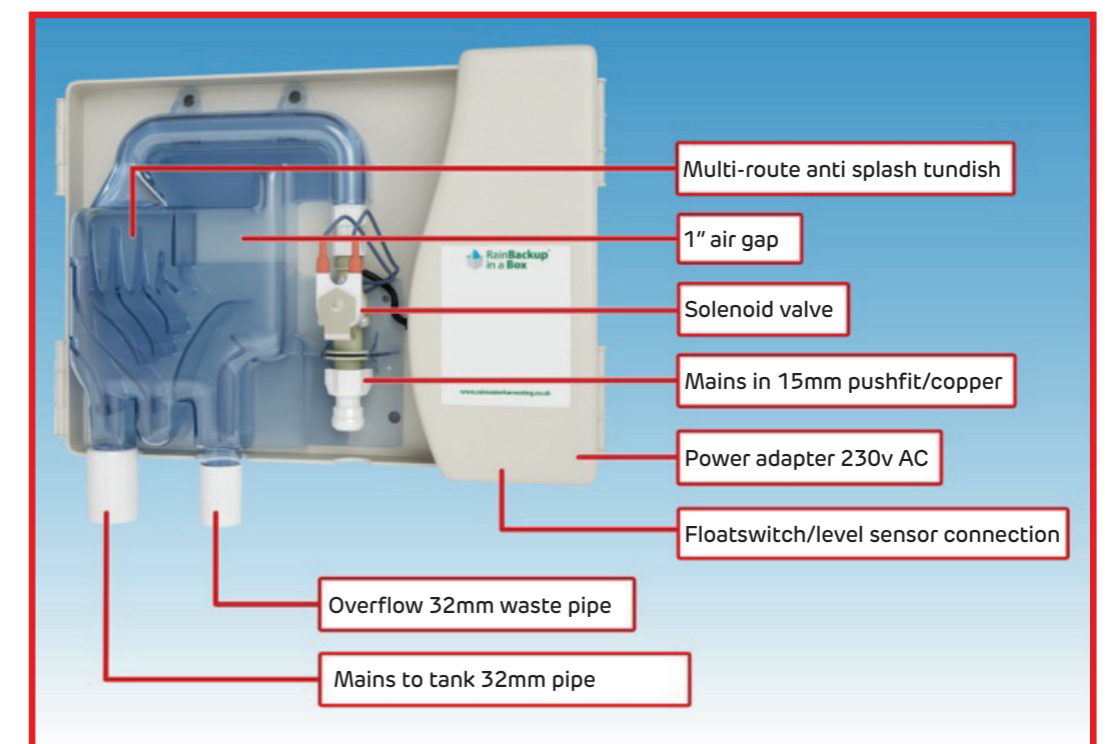

2. TECHNICAL DATA

5) MAKE SURE THE FLOAT SWITCH IS CONNECTED BEFORE THE POWER IS SWITCHED ON

Connect the unit's 12 volt DC adapter to a 220V AC mains socket. Power should be maintained to the unit at all times.

6) The installation is finished. Mains water will continue to flow into the storage tank until water reaches the level sensor. The system will then provide its first timed cycle.

7) Note that the rate of refill of the rainwater tank with mains water by this product is restricted to 4 litres per minute, typically slower than the water flow out of the submersible pump. If you are watering the garden and the rainwater tank runs low it is possible that the pump will shut down due to absence of water, even if the backup mains is flowing. Some pumps need a mains electricity reset (turn switch off and then on).

8) Ensure the water flow is tested from the unit to the tank before the service pipe is covered to ensure there are no flow restrictions.

Wiring instructions

The Backup in a Box SD uses two simple plug connectors.

MAKE SURE THE FLOAT SWITCH IS CONNECTED BEFORE THE POWER IS SWITCHED ON

Connect the unit's 12 volt DC adapter to a 220V AC mains socket. Power should be maintained to the unit at all times.

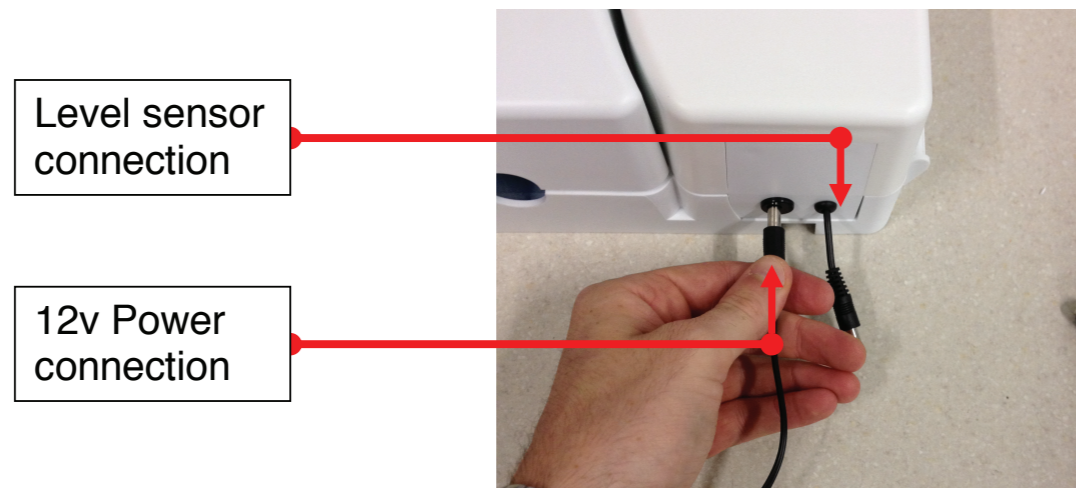

2. TECHNICAL DATA

Types of sensor housing

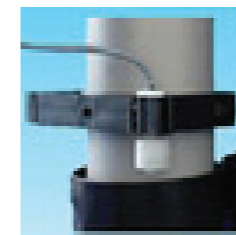

RWH-BUB02-R : The level sensor is housed in a 110mm clip which you would then position around the 110mm pipe inside the tank. For use with all other filters.

Further installation guidance can be found online at: www.rainwaterharvesting.co.uk

Please follow the instructions provided carefully. Not doing so could cause damage to the unit and invalidate the warranty. If you have questions or require assistance please contact one of our technical team:

Graf UK Ltd

Regen House, Beaumont Road, Banbury, Oxfordshire OX16 1RH

T: 01608 661500

F: 01295 211333

E: info@grafuk.co.uk

2. TECHNICAL DATA

Submersible pump

Electrical data and dimensions

Note: Standard scope of supply is Divertron x 900

MODEL	ELECTRICAL DATA							DIMENSIONS										PACKING VOLUME dm ³	Q.TY X PALLET	WEIGHT Kg
	POWER INPUT 50 Hz	P1 W	P2 NOMINAL		In A	CAPACITOR		A	B	C	H	H1	H2	H3	PACKING DIMENSIONS					
			kW	HP		μF	V								L/A	L/B	H			
DIVERTRON 900	1 x 220-240 V ~	920	0,56	0,75	4,2	12,5	450	Ø 160	-	-	536	517	503	596	550	195	250	28,6	32	11
DIVERTRON 650	1 x 220-240 V ~	630	0,42	0,56	2,9	8	450	Ø 160	-	-	488	469	455	548	550	195	250	28,6	32	9,5
DIVERTRON X 900	1 x 220-240 V ~	920	0,56	0,75	4,2	12,5	450	Ø 160	186	33	536	517	503	596	550	195	250	28,6	32	11
DIVERTRON X 650	1 x 220-240 V ~	630	0,42	0,56	2,9	8	450	Ø 160	186	33	488	469	455	548	550	195	250	28,6	32	9,5

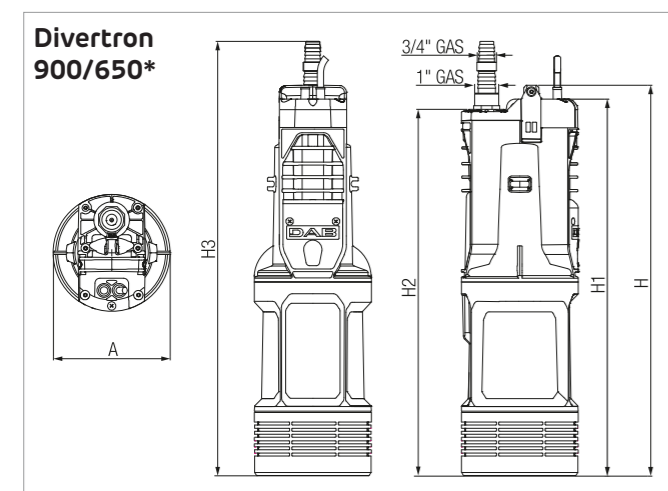

* Same dimensions for models 900 A - 650 A (with float switch)

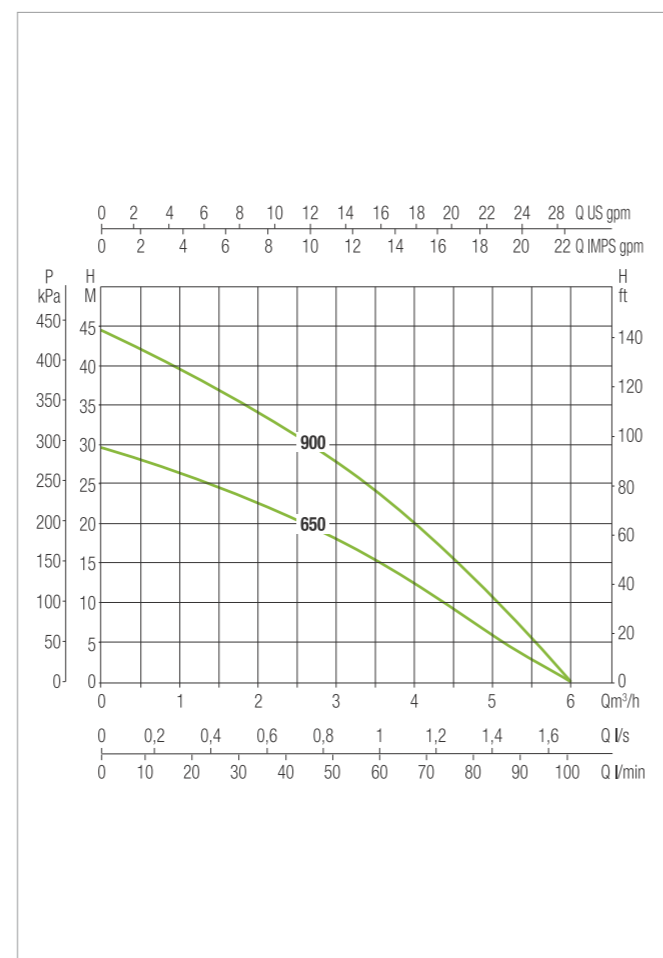
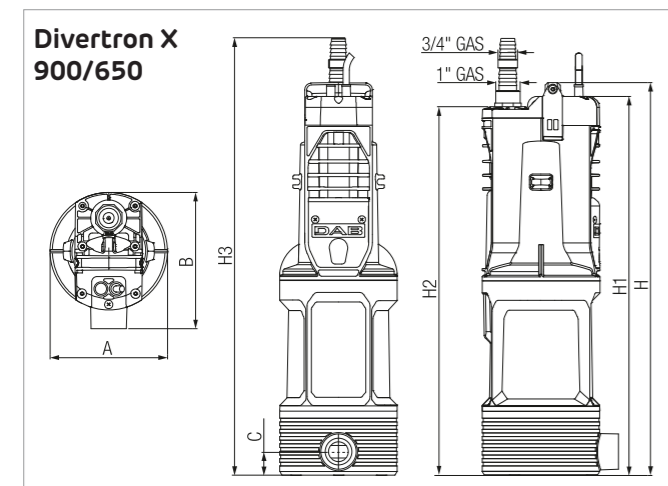

The performance curves are based on kinematic viscosity values = 1 mm²/s and density equivalent to 1000 kg/m³. Curve tolerance according to ISO 9906.

3. INSTALLATION AND ASSEMBLY

Remove the Mains on Tap unit from its transport packaging; in the same box are also the other parts and accessories. Firstly, check the whole equipment for any possible damage. Any damage must be reported before the assembly and installation begins.

3.1 Wall assembly

The Mains on Tap unit must be installed above the back surge level and in a frost free and dry environment that is above any possible regional flood levels.

When choosing a position for installation it is important to be sure that there is at least 50cm free space available above the equipment for any maintenance or adjustment regulation. The wall intended for mounting must be suitable for supporting the equipment with an approximate maximum weight of 2kg when filled with water.

The holes to be drilled are marked out on the wall using the holding brackets as a template and then drilled with a 10mm masonry bit, the holes should be approximately 60mm deep. Press the enclosed dowl plugs into the hole and attach the holding brackets with screws. Finally place the Mains on Tap Unit in position.

3.2 Emergency overflow connection

The emergency overflow is to be constructed with commercial 50mm canalisation pipes for the connection to the mains canalisation. We advise that the emergency overflow should be so constructed with an 86° elbow that a siphon is formed. It is advised that the system may only be installed in rooms with a floor drainage system as in the case of accidental damage to the system may loose water.

When operating normally no water is lost.

3.3 Mains water connection

For connecting the float valve to the mains water supply we recommend using a 3/4" reinforced hose for the installation. **Take care when tightening the supply pipe that the valve does not also twist around problem free operation can no longer be guaranteed.** An additional shut-off valve will also make any future maintenance work less complicated.

Before the installation the mains water pipe system must be well flushed through. A fine filter should be installed to guarantee a long life and trouble free functioning.

Attention:

Line pressure from the mains water max. 0.3 – 4.5 bar!

3.4 Suction pipe connection

A 1" suction pipe is installed in an empty conduit that rises steadily without sagging or bending downward to the connection at the mains water supply point. If this proves to be not possible then an air bleeding valve must be installed at the highest point.

3.5 Pressure hose connection

The connection of the pressure pipe happens at the pressure and flow rate sensor. The further installation to the various individual outlets etc is to be completed with commercial installation pipes (only plastic, use no copper etc). A shut-off valve installed in the pressure lines make any future maintenance work less complicated.

4. INSTRUCTION FOR INSTALLATION AND MAINTENANCE MINIMAX-PRO FILTER INTERNAL

4.1 Minimax-Pro Filter internal

- The MINIMAX-PRO Filter is suitable for installation in a manhole or a underground tank.
- The difference in height between inlet and outlet is around 10 mm with a straight outlet and 80mm with a curved outlet.
- The filter is suitable for roof areas up to 350 m².
- The mesh width of the sieve insert is 0.35 mm.

4.2 Technical Data

Dimensions with curved outlet.

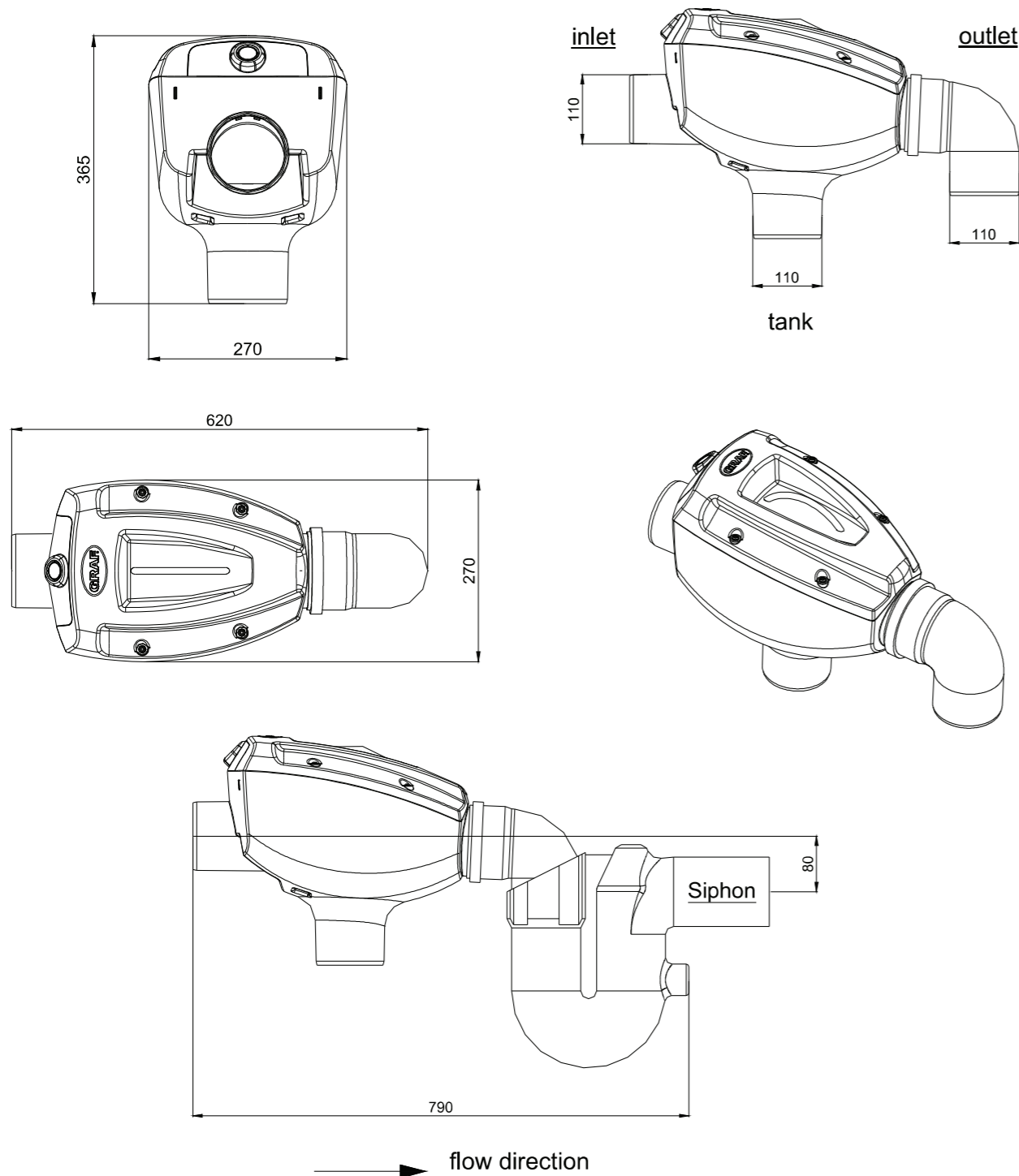

5. ASSEMBLY OF THE GRAF MINIMAX-PRO FILTER INTERNAL

- 1 Clear transparent cover/filter insert
- 2 Housing including nozzle holder
- 3 Outlet bend 87°
- 4 Optional cleaning unit (340040)

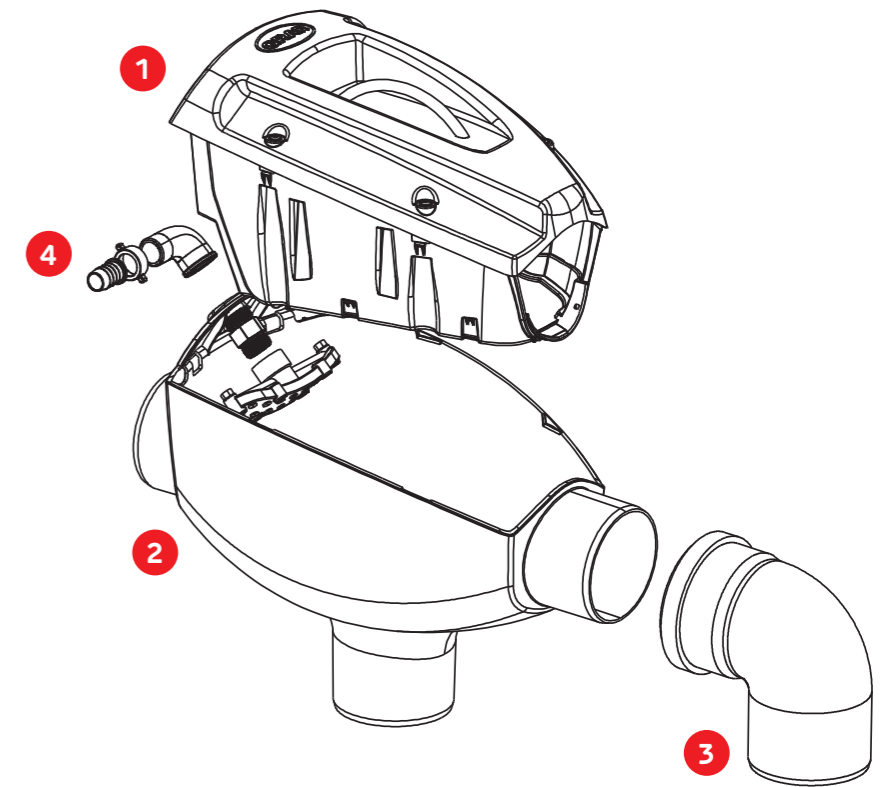

5.1 Overview Platin tank / Filter with curved outlet

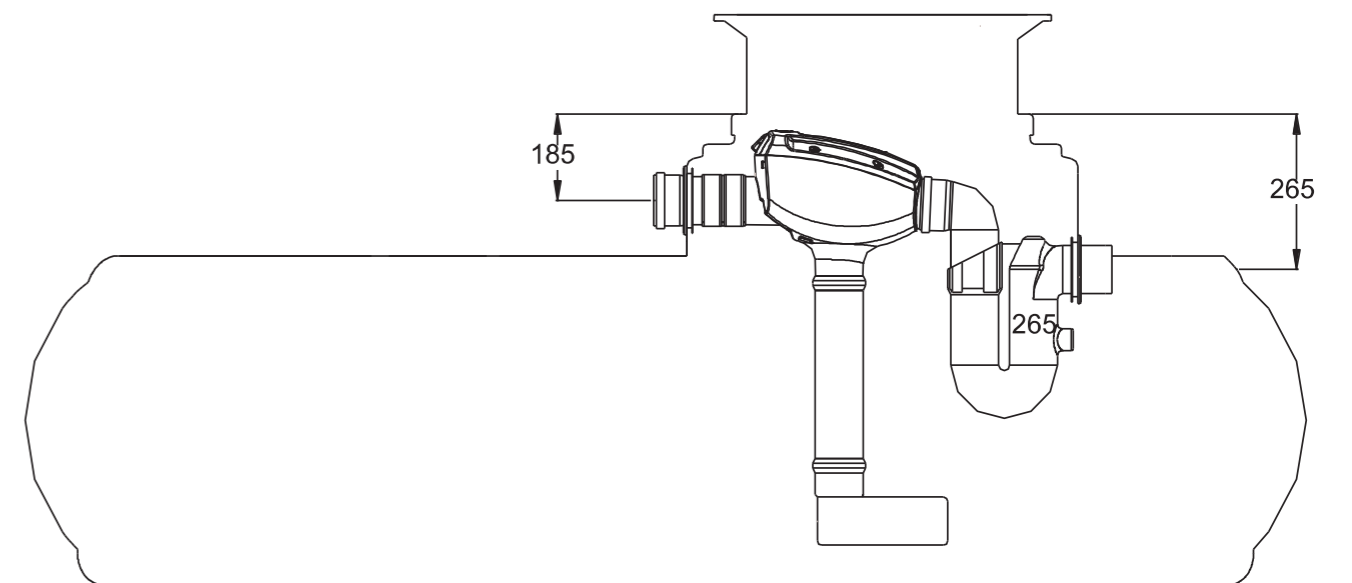

5. ASSEMBLY OF THE GRAF MINIMAX-PRO FILTER INTERNAL

5.2 Installation of inflow pipe and overflow siphon

- 1 Clear transparent cover/filter insert
- 2 Housing including nozzle holder

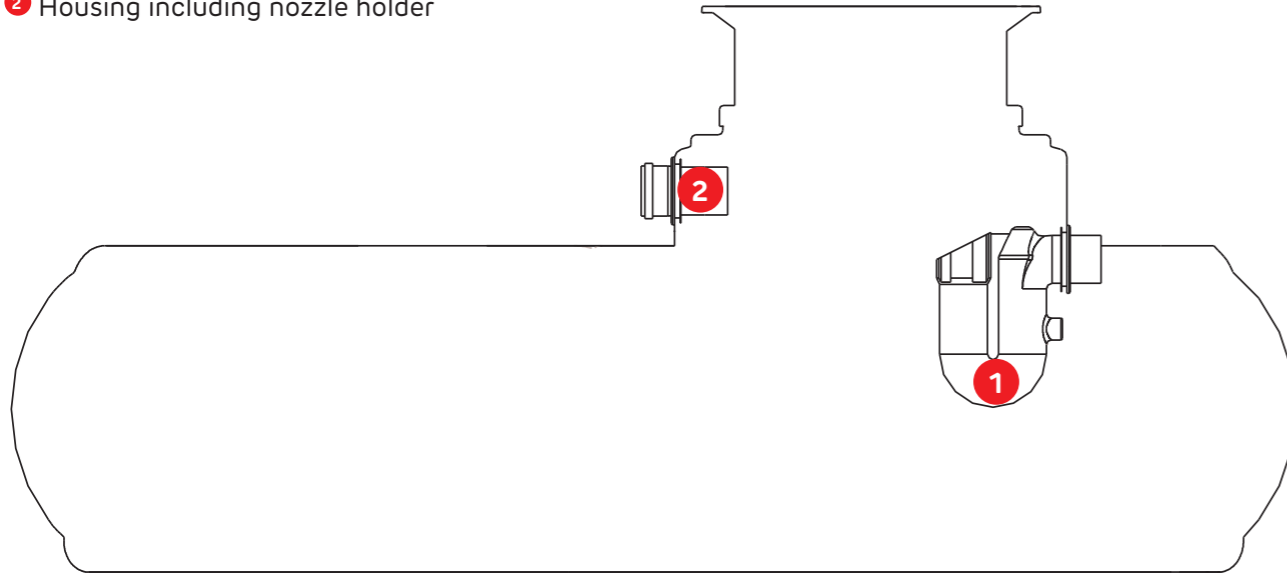

5.3 Preparation filter for installation

Connect the filter body 1 with a PVC pipe DN100 2 (on site) with the inflow calming foot 3 (contained in the filter package 342038).
Secure all connections with self tapping screws to prevent connections separating.

Platin Tank	1500 litres	3000 litres	5000 litres	7500 litres
(L)	470 mm*	500 mm*	675 mm*	1075 mm*

* (+/- 10mm)

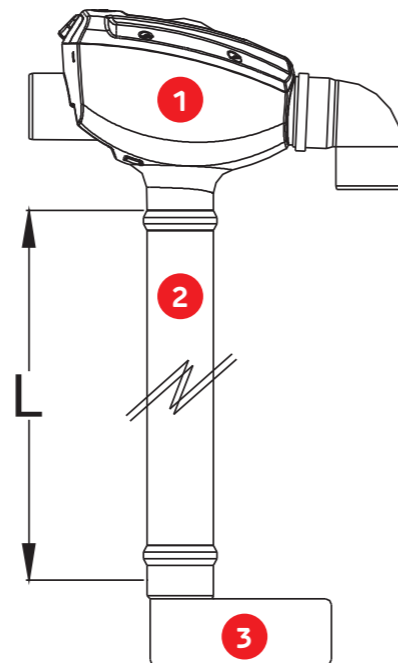

5. ASSEMBLY OF THE GRAF MINIMAX-PRO FILTER INTERNAL

5.4 Insert the filter in to the tank

Insert the filter, prepared with the inflow calming foot, in the tank.
Slide the outlet bend of the filter into the overflow siphon from above, align the supply pipe flush with the filter and then fix with the quick-connection sleeve (included in filter package 342038).

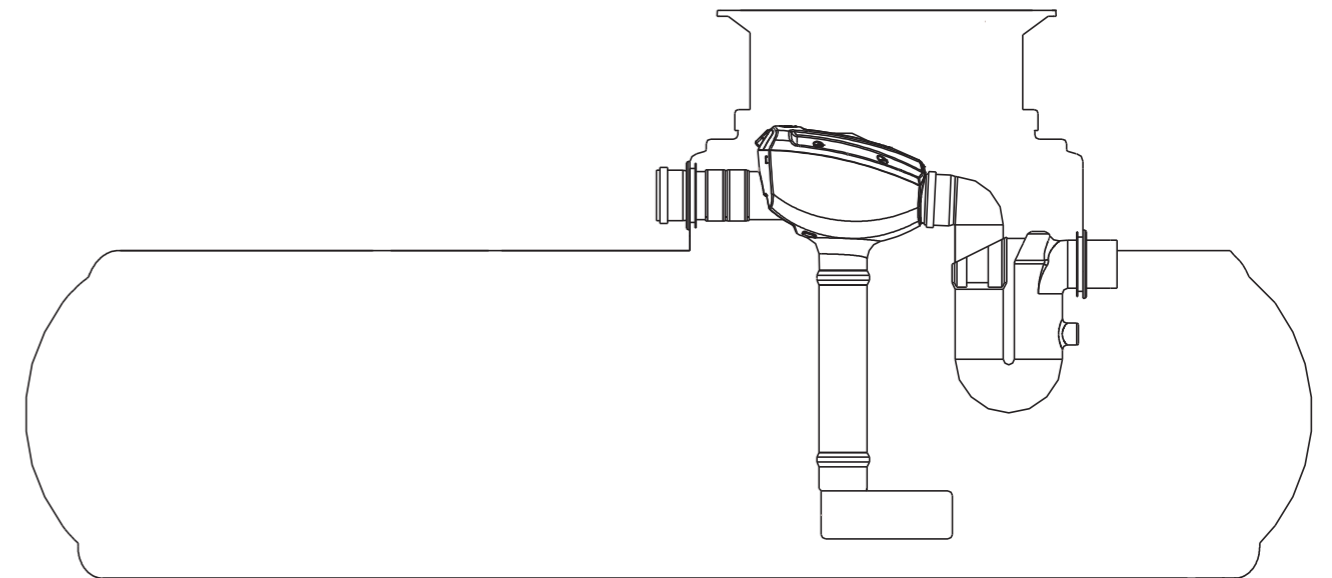

6. INSTALLATION CONDITIONS

6.1 Optimax-Pro Filter internal - Connection DN 100

- The Optimax-Pro Filter internal is suitable for installation in a manhole or a underground tank.
- The difference of level between inflow and outflow is 165 mm.
- The filter is suitable for roof areas up to 350 m².
- The mesh width of the sieve insert is 0.35 mm.

6.2 Optimax XL Filter internal - Connection DN 150

- The Optimax XL Filter internal is suitable for installation in a manhole or a underground tank.
- The difference of level between inflow and outflow is 165 mm.
- The filter is suitable for roof areas up to 750 m².
- The mesh width of the sieve insert is 0.35 mm.

7. TECHNICAL DATA

7.1 Optimax-pro filter internal (DN 100)

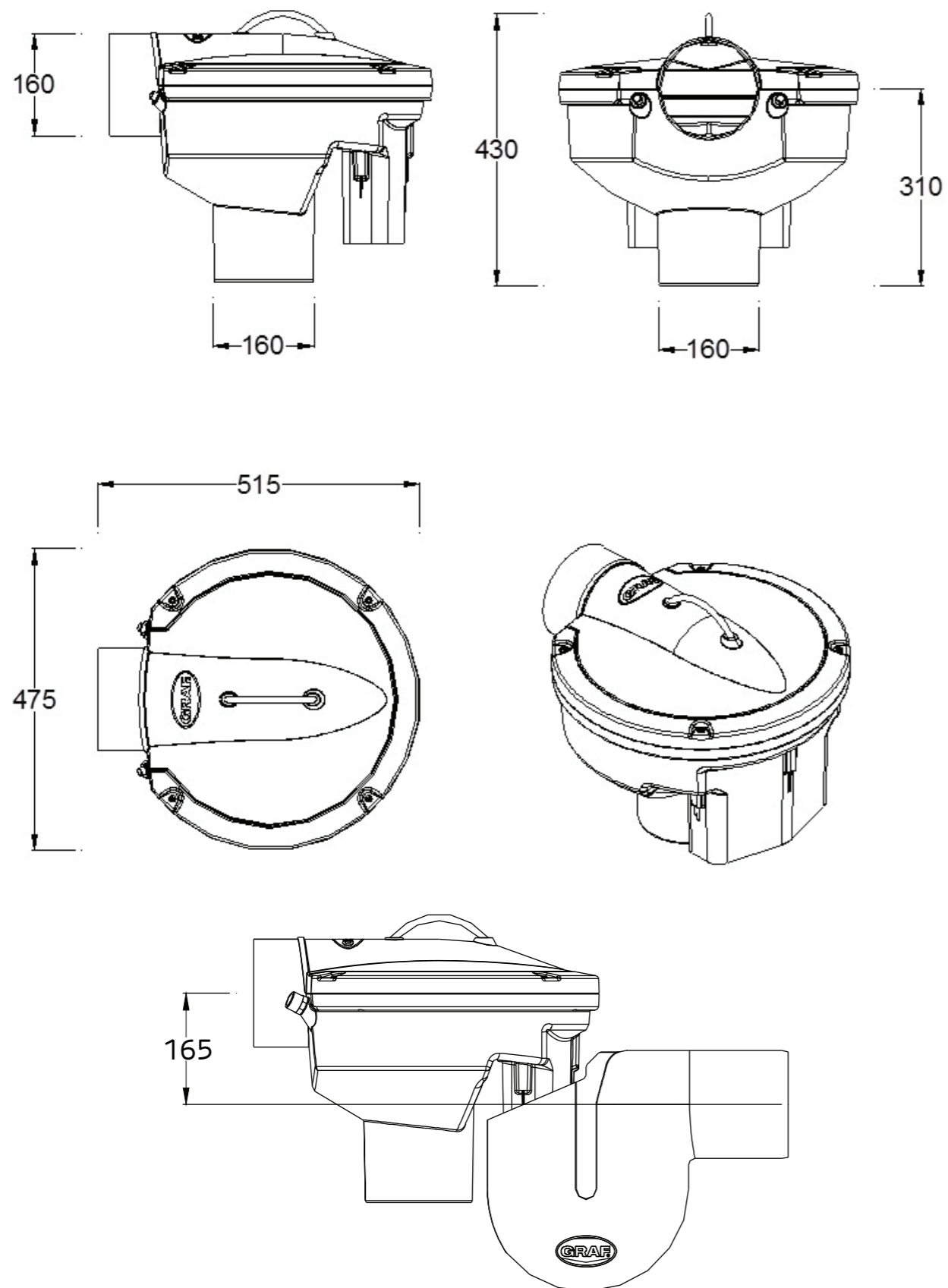

7. TECHNICAL DATA

7.2 Optimax-pro filter internal (DN 100) Assembly

- 1 Clear transparent cover/filter insert
- 2 Filter body including nozzle holder
- 3 Support for Opticlean (340040)

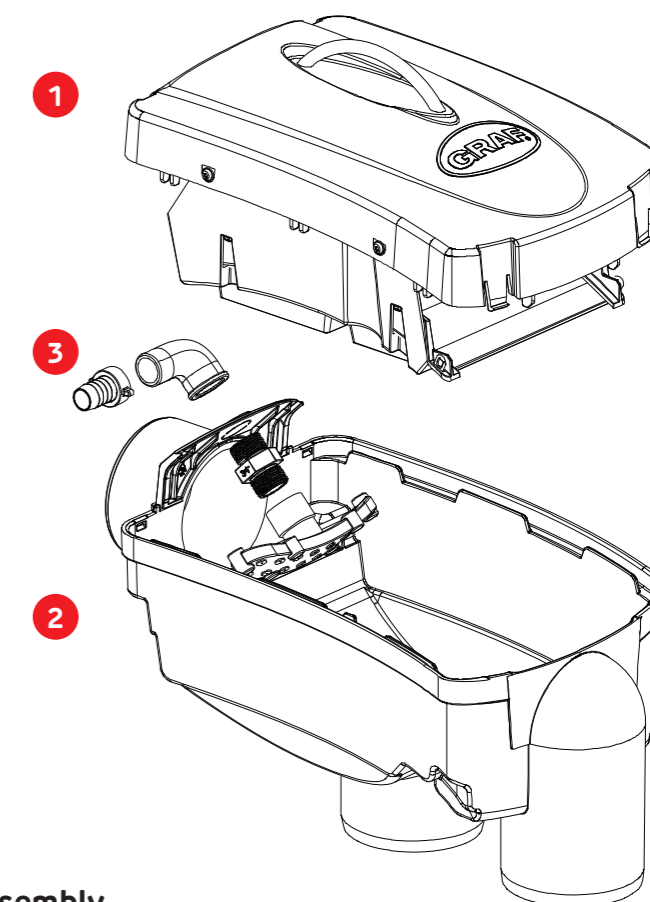

7.3 Optimax XL filter internal (DN 150) Assembly

- 1 Clear transparent cover/filter insert
- 2 Filter body including nozzle holder
- 3 Support for Opticlean (340040)

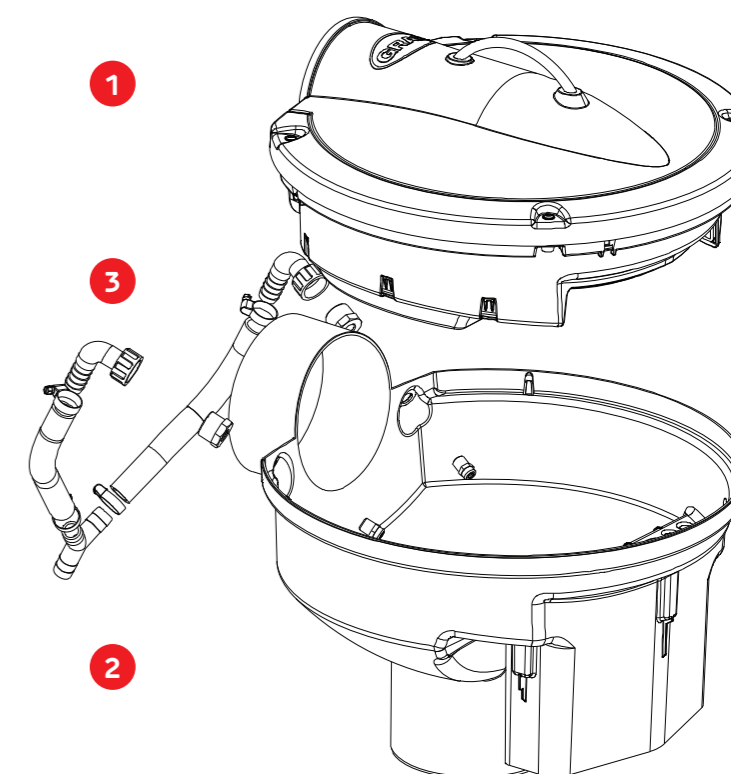

8. INSTALLATION AND ASSEMBLY

8.1 Overview

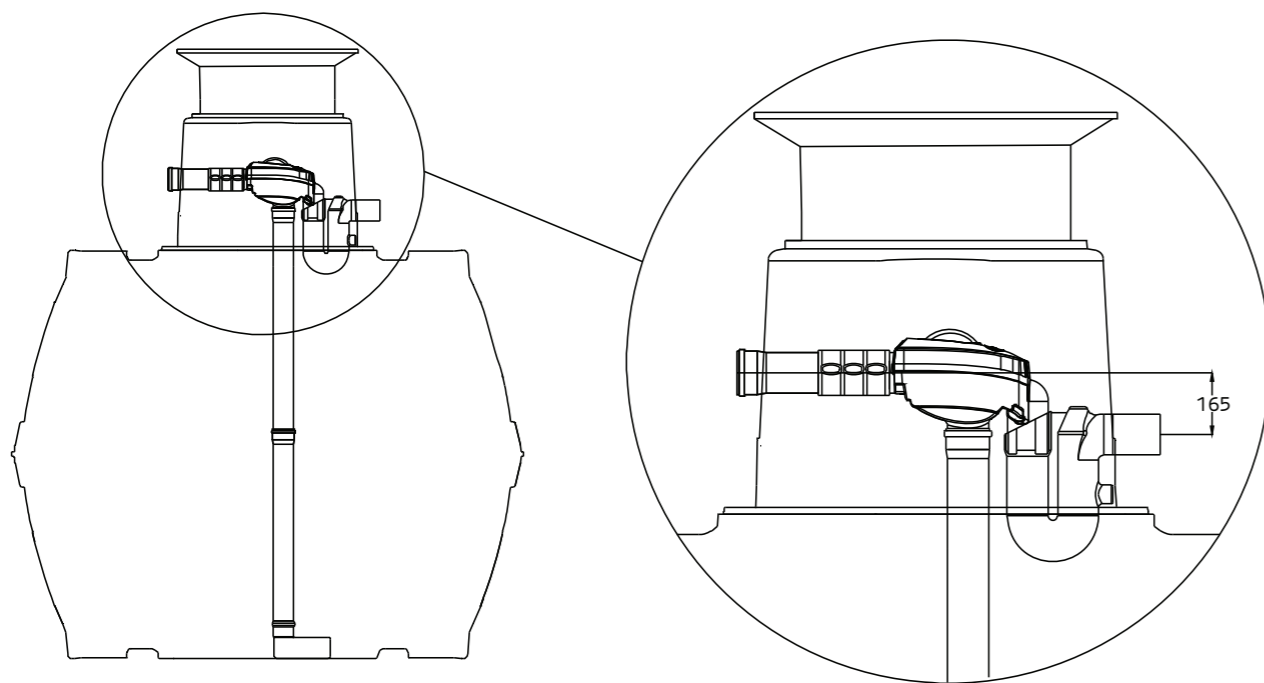

8.2 Installation of inflow pipe and overflow siphon

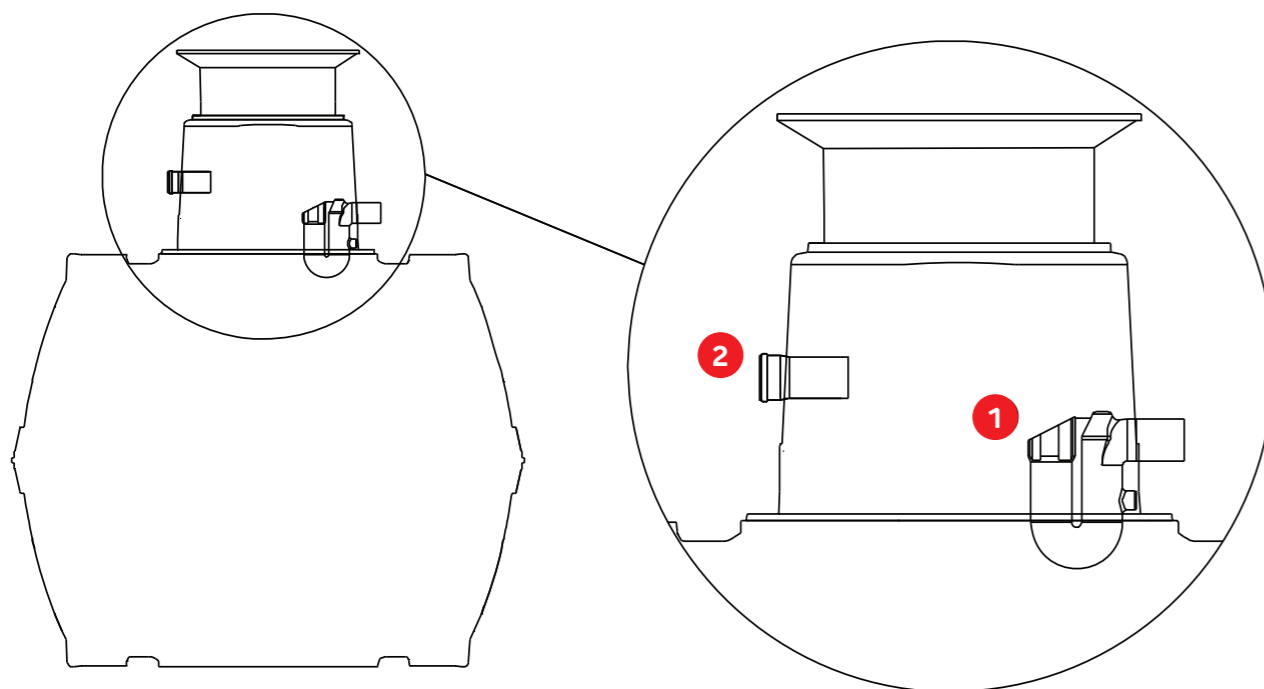

- 1 Insert the overflow siphon in the lower seal.
- 2 Insert the inflow pipe from outside.

8. INSTALLATION AND ASSEMBLY

8.3 Preparation filter for installation

Connect the filter body 1 with a PVC pipe DN 100/150 2 (on site) with the inflow pot (calmed inlet) 3 (contained in filter package 3).
Fix all junctions with screws (against shift of pipes).

Carat volume (liter)	Optimax-Pro Filter internal Connection DN 100*	Optimax XL Filter internal Connection DN 150*
2.700	1320mm	1275mm
3.750	1500mm	1455mm
4.800	1730mm	1685mm
6.500	2020mm	1975mm
8.500	2003mm	1968mm
10,000	2203mm	2158mm
from 16.000	2463mm	2418mm

* (+ / - 10 mm)

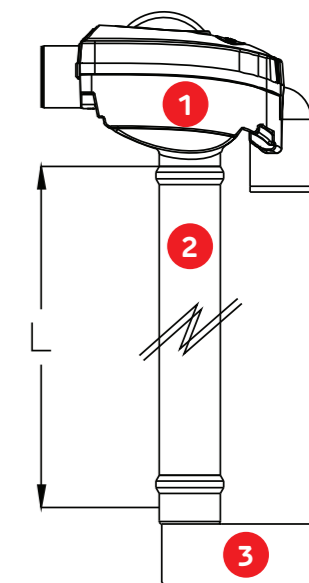

8.4 Insert the filter into the tank

Insert the filter, prepared with the inflow pot (calmed inlet), in the tank.
Telescope the overflow from top into the siphon and fix the filter inflow with the spannfix collar (contained in filter package 3).

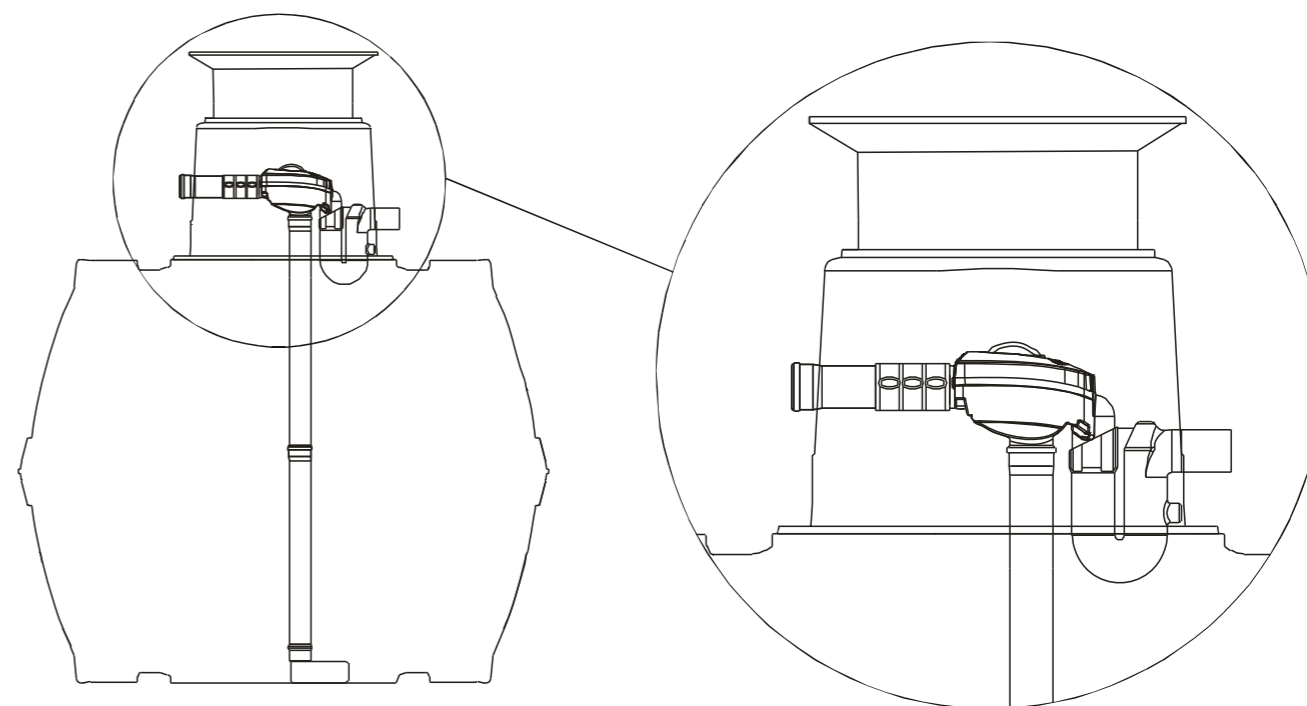

9. ACCESSORY

Handle Plus for Optimax – Pro Filter
Order No. 330220

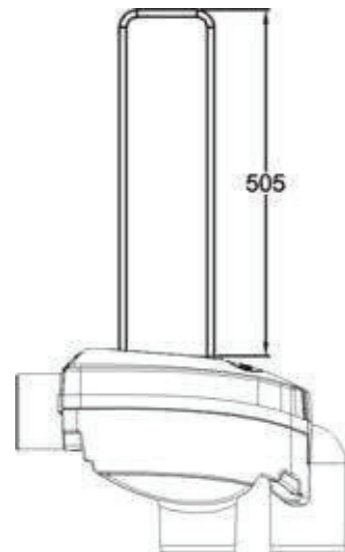

10. INSTALLATION AND MAINTENANCE FOR THE MAINS ON TAP UNIT

The Mains on Tap Unit is a float sensor controlled management system. This unit supplies mains water to the underground tank (via gravity) when the rainwater level is low. i.e. when there is a long period without rainfall.

The rainwater water may be used to water the garden, to flush the toilet, for washing clothes and as conventional cleaning water.

The mains on tap unit must be installed in a frost free and dry environment that is above any flood levels.

Further information regarding the systems specifications, assembly and operation are detailed in the following sections.

10.1 Maintenance

Depending on the dirtiness of the roof surface water the sieve has to be cleaned several times a year. Remove the transparent cover from the filter body. The sieve and the cover is one unit. Removing and cleaning is unproblematic.

11. COMMISSIONING AND SERVICE

Before commissioning and at every inspection, the lifting out mechanism must be positioned at 90° to the inlet so that no large objects such as leaves and twigs can catch on the handle. The straining filter is removed for cleaning and the basket must be thoroughly cleaned with water until all the pores are open. It is advised to clean every 4 to 5 weeks (more often in autumn due to more leaves and twigs) or according to requirements.

The filter strainer basket must be lightly pressed into place taking care that the seal sits precisely after every cleaning.

At the occasion of each inspection, the overflow siphon must be checked and flushed in necessary.

12. GENERAL ADVICE ON SERVICING AND MAINTENANCE FOR THE GRAF RAINWATER HARVESTING SYSTEM

The system must be checked for leaks, cleanliness and stability at least every year.

The entire system should be serviced at intervals of approx. 5 years. In this case, all parts of the system must be cleaned and their function checked. Servicing should be carried out as follows:

- Drain the tank completely
- Clean surfaces and internal parts with water
- Remove all dirt from the tank
- Check that all internal parts are firmly seated
- Check cleanliness of the internal filter in the underground tank
- Check the operation of the submersible pump
- Check the pipe and fitting connections.

The points described in these instructions must be observed under all circumstances. All warranty rights are invalidated in the event of non-observance. Separate installation instructions are enclosed in the transportation packaging for all additional articles purchased from GRAF.

The components must be checked for any damage prior to installation under all circumstances.

Missing instructions can be downloaded on www.graf.info or can be requested from GRAF.



RAINWATER HARVESTING

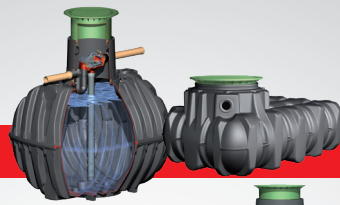

WASTEWATER MANAGEMENT

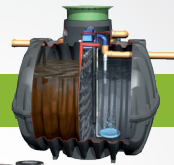

STORMWATER MANAGEMENT



WATER BUTTS & COMPOSTERS



MULTIPURPOSE CONTAINERS



Graf UK Ltd
Regen House
Beaumont Road
Banbury
Oxfordshire OX16 1RH

T: 01608 661500
F: 01295 211333
E: info@grafuk.co.uk
www.grafuk.co.uk

Graf UK Ltd (Scotland)
220 Blairtummock Road
Queenslie Industrial
Estate
Glasgow G33 4ED

T: 0141 465 1540
F: 01295 211333
E: info@grafuk.co.uk
www.grafuk.co.uk