

# User information

*Fill level measuring device and drinking water supply*

**Item no.: 351021**

We congratulate you on the purchase of our fill level measuring device. You have purchased a high-quality product built to the highest standards of modern technology. Before you start to assemble or operate the equipment, please read the user information with care and check exactly the parts supply for completeness.

List of parts supplied:

- The system controls
- The measurement sensor
- Stainless steel probe 3 m long
- 20 m of data carrying cable
- Solenoid valve 230 V with connection cables
- The user information literature
- The installation material with spare fuses

**Otto Graf GmbH**  
**Plastic products**

**Carl-Zeiss-Str. 2-6**  
**D-79 331 Teningen**

**Tel .: ++49(0)7641-5890**  
**Fax: ++49(0)7641-58950**

## **Important notes on safety:**

### **Please, read and follow safety instructions carefully before assembly or using the device!**

During installation and when working with 230 V ~ mains supply the VDE regulations must be followed. Equipment using a 230 V ~ supply may only be installed and commissioned by a qualified tradesman. The assembly place must allow all possible safety precautions when laying the attached cables.

Power supply cables and data cables may not be damaged or squeezed for any reasons. Plan the assembly place so that you can reach the mains plug easily and unplug it from the electrical outlet in dangerous situations.

Choose the assembly place so that children cannot play or be near to the device and at its connections without supervision.

Before opening the device disconnect it from the mains supply (unplug) otherwise there is a serious danger of an electrical shock.

Fuses may only be replaced with standard-compliant parts with the same nominal value.

All liability is excluded for damages which result from non-compliance of these instructions or from an improper handling of the device. At chosen intervals in this hand book we will give directions for safety precautions. These safety precautions have been specially marked.

## **1. Description**

The **AquaControl+** is an electronic water management control system.

It has been developed especially for rain water usage systems. It can be used with a wide variety of tank systems.

Tanks made from metal or steel reinforced cement may only be used when the following conditions have been correctly followed.

Metal tanks lead to faulty readings. Helpful is to assemble the device so that the sensor is as far as possible from the metal sides so for example, in the centre of a cylindrical tank. The system controls offer an easy to use guide for the switch programming. Using an LCD display the fill measurement is shown in 1 % stages (in relation to the height of the tank). The sensor operates with a 12 volt supply. All programmed values such as the tank height are retained after disconnection of the power supply or after a power-cut.

Performance features:

- Fill level measurement readout in 1% steps and with an additional bar type indicator
- In 1% steps freely variable choice of the switching points for the drinking water refill
- Automatic flushing of the system (choice of intervals in day and time are possible)
- Dialog oriented user guidance (choice of language)
- Equipment indication using 3 additional LED
- Supervision of the measurement pick-up and the sensor
- Error indication in simple text

Technical data:

**Control electronics**

**Measurement sensors**

Operating current :	230VAC	Measurement voltage:	12DC
Fused :	T50mA	Measuring frequency:	(0,2-20)KHz
Power consumption:	3VA	Data cable length:	max. 50m
Tank depth:	max. 6m		
Measurements [mm]:	155x165x90	Measurements [mm]:	90x80x50

**Pump connection**

Operating current:	230V AC
Pump performance:	max. 1200VA

**Note:**

*Only the control electronics in the device are protected by the fuse. Valves and pump connections are **not** protected. These are protected only by the mains supply via the mains fuse.*

The following picture shows your newly acquired device:

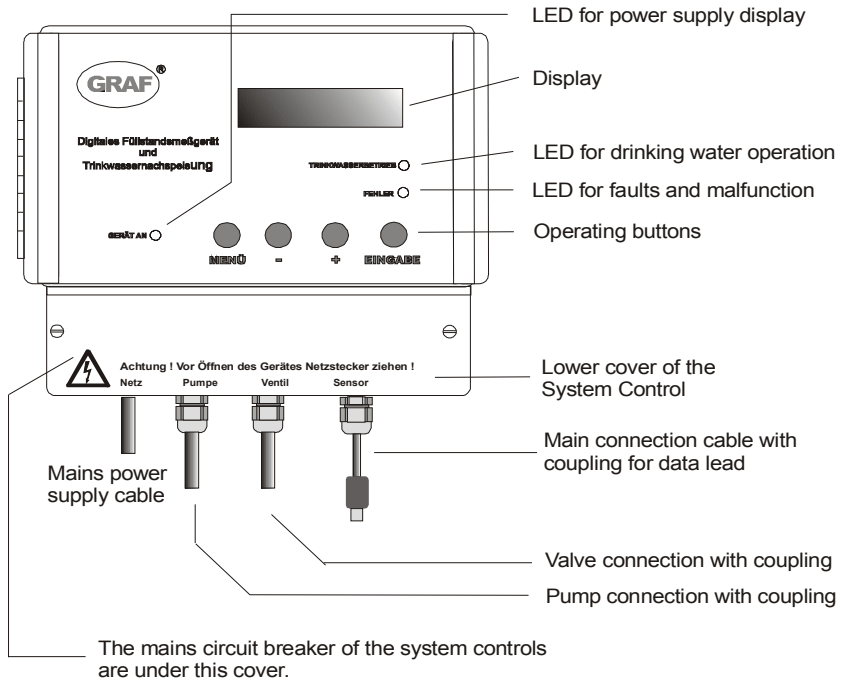

The type identification plate and the serial number are on the left side of the equipment.

*Illustration 1: View of equipment*

## 2. Assembly

### 2.1 Control system

The mains plug of the device serves as an on / off switch.



STOP Before opening the equipment  
pull the plug out from the mains socket !

- Loosen the fastening screws of the lower cover and remove the cover
- Mark out drilling points and drill according to sketch ( see page 19)
- Fasten the device with the enclosed installation material (rawlplugs and screws)

## 2.2 Connection sensors and data cable

The sensor electronics consist of a stainless steel probe with a red and a white connection cable and the sensor pick up element. You next assemble the sensor pick up element (cover open) inside the tank on the side wall (preferably in the tank dome in the 'Graf' synthetic tank). The assembly place of the sensor pick up element should be between 10 cm and 15 cm above the overflow. The enclosed screws should be used for fastening. After completely tightening the screws they should be blunted where they have come through the tanks outer skin to avoid injuries! Thereafter the connecting cables for the sensors must be shortened according to the tank height. Please proceed as follows:

1. Measure the height of the tank from its bottom to the sensor clamp on the pick up element.
2. Shorten the connecting cables according to the height measured (the probe should be taken into account).

Now the sensor cables should be attached to the measurement pick up element as follows.

Strip 5 to 7 mm of the insulation from both cables. Then put the red cable through the screw cap 1 (see illustration 2), tighten the screw cap lightly and connect the red cable to the terminal. The white cable now goes to the screw cap 2 (see illustration 2), tighten the screw cap lightly and connect the white cable to the terminal.

Now pass the plugless end of the data cable through the screw cap 3, lightly tighten the screw cap and connect the wire on the double terminal. The connection to the data cable is reverse polarity protected.

**Attention! Tighten the screws cautiously and do not over tighten; do not strip threads or material!**

**Pay attention to a solid assembly of the Measurement pick up element and check all screws, terminals and caps.**

Close the cover of the Measurement pick up element again and secure it with the fastening screws supplied.

The assembly of the sensor according to good professional practice constitutes the completion of the cable laying for data and system control.

Please use a length of protective tubing for the data cable as this is not suitable for

routing directly underground.

The data cable has a Cinch coupler at the free end. This is plugged into the corresponding socket of the system control.

The following illustration clarifies the context:

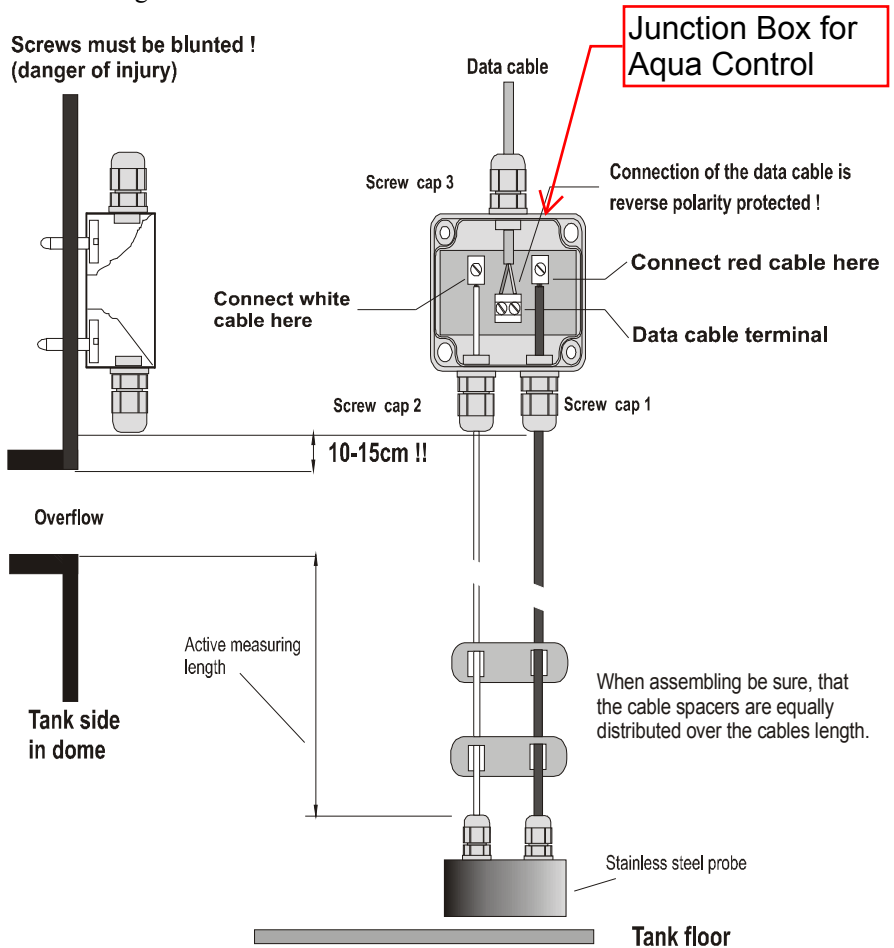

*Illustration 2: Sensor assembly*

The red and the white cable going down to the probe should be straight and smooth to be drawn taught by the weight of the stainless steel probe. The stainless steel probe must hang just above the tank floor. When setting the spacers please be sure to distribute them equally over the complete length as shown in illustration 2.

### 2.3 Electrical connection of the filter flushing valve

The connection of the valve to clean of the rain water filter is **optional**. The software of the device already contains all necessary programme parts. For an extra charge the hardware can be retrofitted by the manufacturer. In such a case please consult your service partner.

### 2.4 Connection of the solenoid valve

Connect the plug of the solenoid valve with the centre coupling of the control electronics (see illustration 1).

## 3.Commissioning

Before the putting the equipment into operation check and be sure that all electrical connections are correctly insulated and all covers are properly closed

Now open the transparent cover of the system controls. Plug the equipment into the mains socket (this socket must be exclusively for the equipment and be on its own fuse). The system then runs a system check through automatically

For the duration of the system check (approx. 10 seconds) the following signal will be displayed in the window:

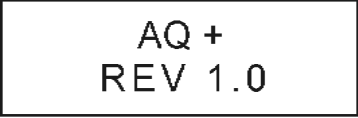

AQ +  
REV 1.0

*Illustration 4: Display during the equipment check*

The equipment type is shown on the first line and the software check in progress is shown in the second line.

If after the initial installation check all is correct, the LCD indicator will display the fill level (in %).

**The filling level shown will be according to the value programmed for the tank height as set in the factory.**

## Factory adjusted values:

- Tank height to overflow: 200cm (+/- 1cm)
- Switching points dry run protection: pump on at 8%  
pump off at 6%
- Switching points valve : Valve on at 10%  
Valve off at 12%
- Flushing the drinking water supply system: 14-day for 30 seconds
- Cleaning of the rain water filter \*: 14-day for 5 seconds with rain water
- Language: English

"\*" function is optional

The illustration 5 shows the LCD-display in the operation mode. The display shows the filling level and the operating modes as abbreviations: "FV" and "P". These abbreviations correspond as follows:

- FV+ : filter valve opened
- FV- : filter valve closed
- P+ : (pump on) house waterworks in operation
- P- : (pump off) no water currently being withdrawn

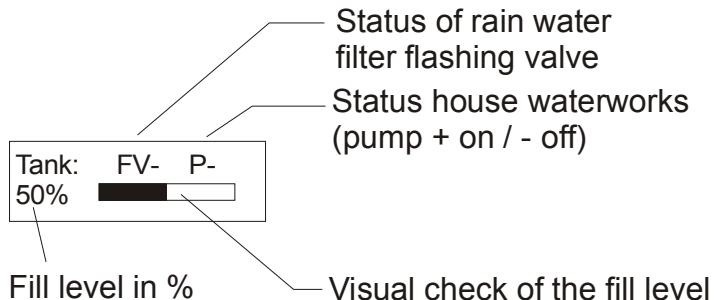

*Illustration 5: Display in the operation mode*

## 4. Adjusting the system control

After putting into operation it is necessary to adjust the system controls according to the exact existing conditions. The adjustment is possible with simple tools and four buttons for entering data. All required data input is carried out via menu control on the LCD-display. For adjustment carry out all the points listed in Table 1 in the correct order. If you should have inadvertently mixed up the order, please start once more at the adjustment of the tank height.

With pressing the button "**menu**" you start the adjustment process.

With the buttons "+" or "-" the menu may be scrolled forwards or backwards.

The entries may be altered in the respective menu point.

Now please press the "**ENTER**" button. The "?" shown in the LCD-display then changes into a ">" - symbol. With the symbols "+" or "-" adjustments may be made to the appropriate values according to your requirements. Once the desired value is reached, this value **must** be confirmed by pressing the button "**ENTER**." Only then is the value taken and stored by the device. By a pressing the button "**menu**" once more you revert back into the operation mode.

You may revert to the factory set system control standard adjustment values at any time.

This return can only be carried out in operation mode (see display in illustration 6):

Next press the "**ENTER**" button and **keep it pressed down.**  
**In addition** press the button "**menu**".

After a short time there then appears the following display:



*Illustration 6: Value adjustments returned to the factory settings.*

When you see this in the display, you may release the buttons.

**Note:**

*If necessary the Equipment restarts.*

**Order of alignment adjustments:**

<b>Button</b>	<b>Function</b>	<b>unit</b>	<b>comment</b>
Menu	Height of tank	cm	
+	Valve ON SPkt	%	Switch over valve drinking water
+	Valve OFF SPkt	%	Switch over valve drinking water
+	Pump ON Spkt	%	Pump switch on point
+	Pump OFF Spkt	%	Pump switch off point
+	DwatFlush int.	Days	Drinking water flushing interval.
+	DwatFlush dur.	Seconds	Drinking water flushing duration
+	FiltFlush int. *	Days	Rain filter water flushing interval.
+	FiltFlush dur. *	Seconds	Rain water filter flushing duration.
+	UV Lamp int.	Days	
+	UV Lamp dur.	Seconds	

"\*" Function is optional

*Table 1: Order of alignment adjustments:*

**Note:**

*There exists a further menu point "device general". this includes specific settings that must not necessarily be altered when making adjustments. An explanation is*

given in the section "special equipment settings".

Once you have coordinated your system, the display shows the current fill level of your rain water reservoir in % and by a bar display.

Hand operation of the two valves is possible when the system or pump is running. *An explanation is given in the section "special equipment settings"*

The possible ranges of adjustment may be gathered from the following table:

Switch over valve on drinking water:	ON 0% to 100%
	OFF 0% to 100%
Dry run protection pump:	ON 0% to 100%
	OFF 0% to 100%
Drinking water flush Interval:	0 to 14 days
Drinking water flush duration:	0 to 60 seconds
Rain water filter flush interval*:	0 to 14 days
Rain water filter flush duration*:	0 to 60 seconds
Tank height	0.3 m to 6 m (6 m sensor must be ordered extra)
UV Lamp Range (interval)	0 to 14 days
UV Lamp Continue (duration)	0 to 60 seconds

\* "function is optional"

## 5. Programming technical notes:

The system control reverts to the operation mode automatically if no new information is entered into the programme menu or input menu for a duration of approximately 30 seconds.

The switching point for the switch over valve to drinking water "Valve ON Setpnt" **must** be below the switching off point "Valve OFF Setpnt".

The function "flushing the rain water filter" is executed automatically, as soon as the fill level has increased in the tank by 2% or the time set in the menu has been reached (Optional).

The yellow LED "drinking water operation" comes on as soon as the drinking water supply valve has switched over. You will be alerted that drinking water is now in use.

The red LED "Error" is clear, as soon as a fault is recognized by the device. A reference to the cause is then given in the plain text on the display. The announced reports always represent only probabilities; therefore no clear localization by the device is possible for overlapping faults.

***Please take into account that faults in the house water supply system are not recognized by the system control.***

*(There are no error messages from the house water supply system transmitted to the system control).*

## **6. Error messages and fault correction:**

**The operation of the system control is to be checked at regular intervals (at the latest every 4 weeks).**

If faults are recognized by the sensors the system control cannot continue to work independently.

The particular faults are shown on the plain text in the display:

You receive the report "sensor error":

The cause for this fault is damage to the white sensor cable. In this case you should remove the sensor from the water. If there is no further error reported then it is necessary to replace the sensor. For the replacement sensor please contact your service partner.

You receive the report "sensor system error":

In this case there are two possible causes for the error: The sensor pick up element or the measurement equipment in general. For the further diagnosis please take the sensor out of the water. If the shown error indication has gone then the sensor was lone the cause. If the error message is still there, it is the sensor pick up element that is faulty. Please get in contact with your service partner for replacement of the sensor or the measurement value recorder.

You receive the error message "data line short-circuited":

Also in this case there are several possibilities. First check whether the data cable on the measurement value recorder is connected to the data cable terminal and not to the sensor cable terminal. Furthermore check the Cinch plug and the Cinch socket for a short circuit or other damage. As last possibility the wires of the data cable could have been damaged. If you still cannot find the cause of the problem, please contact your service partner.

You receive the error message "sensor pick up element error":

The sensor pick up element does not deliver a signal and must be replaced; please contact your service partner.

You receive the error message "no sensor system found":

The connection of the system control to the sensor pick up element is interrupted or is not available. Please check all connections to the data cable. (At the sensor pick up element, the Cinch plug and the Cinch terminal) Please also remember that the data cable could have been damaged by digging work.

If the device shows no function at all then check whether the main electrical supply provides current and also check the house fuses.



STOP Before opening the equipment  
pull the plug out from the mains socket !

If the electrical outlet is under current, then unplug the mains plug from the system control.

Without connection to current open the lower cover of the system control (see illustration 1) and check the equipments mains fuse.

If your efforts are unsuccessful, please consult the manufacturer:

A+S Aktuatorik und Sensorik GmbH  
Franz – Wienholz- Str. 16  
D-17 291 Prenzlau  
Tel.: ++49 (0) 3984 – 80 87 17

Internet: [www.aktuatorikundsensarik.com](http://www.aktuatorikundsensarik.com)  
E-Mail: [info@aktuatorikundsensarik.de](mailto:info@aktuatorikundsensarik.de)

Please have the serial number of the device ready when you call! The serial No. is to be found on the Serial number plate on the lower cover of the system control (see illustration 1).

Please also find the relevant information on the Internet under:

[www.aktuatorikundsensarik.com/FAQ/faq.html](http://www.aktuatorikundsensarik.com/FAQ/faq.html)

## 7. Special equipment settings

The special equipment settings are obtained by pressing the "Menu" button and then leafing through with the "+" or "-" button, run through until the following message is displayed.

Set up general  
Langua. / Mode ?

### *Illustration 7: Menu for the equipment adjustment*

By pressing the button "Enter" you go a level down. Also in this lower level it is possible to leaf through with the "+" or "-" buttons. By pressing the button "Enter" the new settings will be confirmed and to leave the lower level again you press the "**menu**" button .

You can select the devices language in the first submenu of the 2nd level. For the selection you use the button "+" and for the confirmation of your choice you push the "Enter" button.

Language  
D GB F : >

### *Illustration 8: Menu for the language settings*

For diagnosis purposes use the second submenu of the 2nd level.

The number of days passed since the last flush of the drinking water supply system is shown here. Please take into account that a power failure in the most unfavourable case a "loss of time" for the flushing function of max 6 hours plus the time for the power failure could occur (the system control stores internally the time until the flush of the drinking water supply only every 6 hours).

Since the device doesn't have a real time clock with speed reserve such a "loss of time" does not represent any reason for complaints as the time "flush drinking water supply" is reset as soon as the system control returns to drinking water operation (e.g. by a too low fill level).

Flush time DW  
0-14 Tage: xx

*Instead of "xx" you see the number of days.*

*Illustration 9: Menu for the indication of the time passed since the last flush of the drinking water supply*

The third submenu of the 2nd level may also be used for diagnosis purposes. The days since the last flush of the rain water filter are displayed here (**optional**). Please take into account that a power failure in the most unfavourable case a "loss of time" for the flushing function of max 6 hours plus the time for the power failure could occur (the system control stores internally the time until the flush of the drinking water supply only every 6 hours).

Such a "loss of time" also doesn't represent any reason for as the time "flush rain water filter" is reset if the rain water filter has been flushed or there has been rainfall resulting in a more than 2% fill level difference.

Flush time filt.  
0-14 Tage: xx

*Instead of "xx" you see the number of days.*

*Illustration 10: menu for the indication of the time since the last flush of the rain water filter*

The fourth submenu of the 2nd level is for the possible hand operation of the drinking water flush.

Hand flush DW  
active >N

*Illustration 11: menu hand operation drinking water flush*

The question mark is removed by pressing the Enter button and with the "+" button the flushing is activated. The display then shows:

Hand flush filt.  
active >J

*Illustration 12: menu drinking water flush activated*

Now press the "Enter" button and the following will be displayed:

Hand flush DW  
ON J

*Illustration 13: menu activated drinking flush; wait for water withdrawal*

The flush with drinking water has been activated.

To finish the process you press the button "+" and then the button "Enter". For safety reasons the flushing function ends after approx. 70 seconds automatically.

The fifth submenu of the 2nd level makes possible the hand operation of the rain water filter flush (**optional, depending on integrated hardware possible**).

Hand flush filt.  
active >N?

*Illustration 14: menu hand operation rain water filter flush*

The question mark is removed by pressing the Enter button and with the "+" button the flushing is activated. The display then shows:

Hand flush filt.  
active >J

*Illustration 15: menu activated flush rain water filter*

Press the "Enter" button. The display then shows:

Hand flush filt. ON            J
-------------------------------------

*Illustration 16: menu "rain water filter flush" in operation*

The flushing of the rain water filter is immediately carried out because the house water system (or the pump) runs immediately with the activation of the filter solenoid valve. To end the rain water flushing cycle press the "+" button followed by pressing the "Enter" button.

**Attention!**

**The flushing cycle of the rain water filter is complete only after having pressed the "Enter" button.**

**For safety reasons the flushing of the rain water filter ends automatically after approx. 1.5 minutes to prevent pumping the tank completely empty.**

## **8. Electrical wiring diagram**

The AquaControl+ offers the rain water system a dry run protection for the pump or the house water system. So that the dry run protection will function properly the rain water system must be wired according to the following diagram.

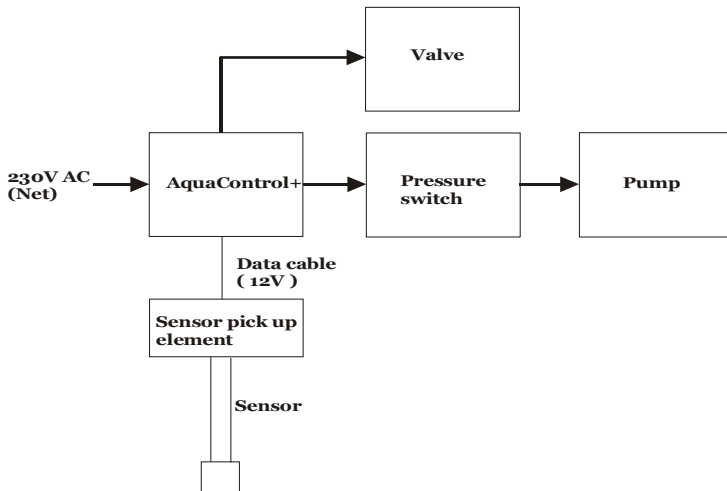

*Illustration 17: electrical wiring diagram*

Note:

*Should the existing pump or house water system already have a dry run protection it may be appropriate and is possible to order the AquaControl+ without a dry run protection.*

## 9. Enhancement possibilities:

With this purchase you have a standard design with all the functions **necessary** for a rain water system.

Some additional functions are already integrated in the equipment software and may be used after changes in the equipment hardware: These alterations will incur charges.

- The flushing function for the rain water filter
- A potential-free error indicator contact (converter element, 230 VAC, max. 1 A)

In the course of the further development of our products there are further additional functions planned. You can always find the current information on the Internet: [www.aktuatorikundsensarik.com](http://www.aktuatorikundsensarik.com)

## 10. Drilling outline

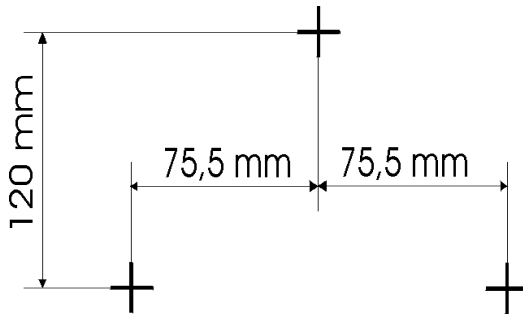

*Illustration 18: Drilling outline for housing outline*

Room for your notes:

Purchase date: .....

Device serial number / Type: .....

Tank height: .....

Software level: .....

Design and specifications are subject to change without notice  
Dated: February 2004 version: AQX 1.0